

2216 Nways Multiaccess Connector



Service and Maintenance Manual

2216 Nways Multiaccess Connector



Service and Maintenance Manual

Note

Before using this information and the product it supports, be sure to read the general information under Appendix G, "Notices" on page G-1.

Third Edition (December 1997)

This edition applies to the IBM 2216 Nways Multiaccess Connector Model 400.

Order publications through your IBM representative or the IBM branch office serving your locality. Publications are not stocked at the address given below.

A form for readers' comments appears at the back of this publication. If the form has been removed, address your comments to:

Department CGF
Design & Information Development
IBM Corporation
PO Box 12195
RESEARCH TRIANGLE PARK NC 27709-9990
USA

When you send information to IBM, you grant IBM a non-exclusive right to use or distribute the information in any way it believes appropriate without incurring any obligation to you.

© **Copyright International Business Machines Corporation 1997. All rights reserved.**

Note to U.S. Government Users — Documentation related to restricted rights — Use, duplication or disclosure is subject to restrictions set forth in GSA ADP Schedule Contract with IBM Corp.

Contents

About This Manual	vii
Who Should Read This Manual	vii
2216 Library Overview	ix
Visit our Web Sites	x
Information, Updates, and Corrections	xi
Summary of Changes	xii
Chapter 1. Problem Determination	1-1
2216 Power Supply	1-1
System Card LEDs	1-1
LED Indicators	1-2
Power Supply Status	1-3
System Card Status	1-3
Adapter Card Status	1-3
Important Phone Numbers	1-3
Troubleshooting	1-4
Diagnosing Hardware Problems	1-4
Diagnosing Operational Code and Configuration Problems	1-4
MAP 0600: 2216 Basic Verification	1-5
MAP 0610: Service Terminal Display Unreadable	1-10
Service Kit—Feature Code 2505 (PN 85H5541)	1-14
Chapter 2. Removal and Replacement Procedures	2-1
Before You Start	2-1
Equipment You Need	2-1
Safety Precautions	2-1
Disconnecting the Power Cord	2-1
Reconnecting the Power Cord	2-2
2216 FRU Exchange	2-3
Exchanging a Power Supply	2-4
Exchanging the System Card	2-5
Exchanging the Hard Drive on the System Card	2-8
Installing Operational Software on the New Hard Drive	2-10
Exchanging the Memory on the System Card	2-11
Exchanging the Fan Tray	2-13
Exchanging an Adapter	2-14
Exchanging the Backplane	2-18
Chapter 3. Accessing the 2216	3-1
Access Methods	3-1
SLIP Addresses	3-3
Serial Port and PCMCIA Modem Default Settings	3-3
Attaching an ASCII Terminal	3-3
ASCII Terminal Setup Attributes	3-3
Terminal Settings and Function Keys	3-4
Managing the Operational and Configuration Software	3-5
IBM 2216 Software and Configuration Change Management	3-5
Chapter 4. Using 2216 Firmware	4-1
Supervisory/Attended Mode	4-1

Unattended Mode	4-1
Starting Firmware	4-2
The Function Keys	4-2
Obtaining Help	4-2
Managing the Configuration	4-3
Selecting the Boot Sequence	4-5
Selecting a Device To Test	4-7
Using the Utilities	4-8
Setting the Power-On Password	4-9
Setting the Supervisory Password	4-10
Enabling Unattended Start Mode	4-11
Disabling Unattended Start Mode	4-12
Removing the Supervisory Password	4-13
Updating System Firmware	4-14
Displaying the Error Log	4-16
Viewing or Setting Vital Product Data	4-17
Setting Up Remote Initial Program Load	4-19
Manipulating the Dead Man Timer	4-20
Change Management	4-21
Chapter 5. Using Operational Diagnostics	5-1
Overview of Diagnostic Functions and Status Information	5-1
Using the Command Line Interface Operational Diagnostics	5-2
Testing the Adapters	5-8
Powering On the IBM 2216	5-8
Running Diagnostics on the Adapter	5-9
ESCON-only Tests	5-12
Run the Light Test on the New Fiber Optic Cable	5-12
ESCON Interactive Test Options	5-15
ESCON Optical Power Measurement Test	5-16
Appendix A. Hardware Error Codes	A-1
Appendix B. Parts Listing	B-1
Assembly 1: Final Assembly, 2216 - Model 400	B-2
2216-400 Feature Codes	B-4
2216 Feature Card Cables	B-5
Appendix C. Hardware Characteristics	C-1
Physical Specifications	C-1
Weight	C-1
Service Clearances	C-1
Airflow	C-1
Operating Environment	C-1
Lightning Protection	C-2
Electromagnetic Interference	C-2
Power Supply	C-2
Power Supply Requirements	C-2
Power Cord Characteristics	C-2
Appendix D. Managing Operational Code and Configuration Files	D-1
Reconfiguring	D-1
How Software Files Are Managed	D-1
How to View the Files	D-1

How to Reset the IBM 2216	D-2
File Transfer Using TFTP	D-2
File Transfer Using Xmodem	D-4
Migrating to a New Code Level	D-5
Using the Configuration Program to Manage the Configuration Files	D-6
Change Management Functions	D-8
Using the Copy Command	D-9
File Transfer	D-9
Appendix E. Adapter Plugging Defaults	E-1
Plugging Sequences	E-1
Slots and Adapters	E-2
Appendix F. Common Tasks	F-1
LED States / Adapter Status	F-1
The Firmware Interface	F-1
Command Line Interface	F-1
Navigating Through the Command Line Interface	F-1
Displaying List of Configured Interfaces	F-2
Displaying the Operational State of the Interfaces	F-3
Verifying Connectivity	F-3
Viewing Vital Software Data	F-3
Viewing Vital Hardware Data	F-4
Adding an Adapter at Initial Configuration	F-4
Adding an Adapter after Initial Configuration	F-5
Running Quick Configuration	F-6
Disabling an Adapter Port	F-6
Enabling an Adapter Port	F-6
Suspend Traffic on an Adapter Port	F-7
Resume Traffic on an Adapter Port	F-7
Removing and Deleting an Adapter	F-8
Up-to-Date IBM 2216 Information	F-8
Disabling Interfaces that Have WAN Reroute Enabled	F-8
Enabling WAN Reroute after You Have Disabled it	F-9
Remote File Download	F-9
Spare Interfaces	F-11
Appendix G. Notices	G-1
Electronic Emission Notices	G-1
Japanese Voluntary Control Council for Interference (VCCI) Statement	G-2
CISPR22 Compliance Statement	G-2
Taiwanese Class A Warning Statement	G-2
European Union (EU) Mark of Conformity Statement	G-3
Telecommunication Notices	G-4
United Kingdom Compliance Statement	G-6
Trademarks	G-6
Appendix H. Safety Information	H-1
Caution Notices	H-5
Glossary	X-1
Index	X-11

About This Manual

This manual provides the service representative with the information needed to:

- Analyze a problem or symptoms reported by the user
- Restore normal operation to the 2216
- Exchange any of the FRUs of the 2216
- Run firmware and operational diagnostics.

Who Should Read This Manual

This manual is for the use of the person providing level 1 remote support of the IBM 2216. Also, IBM service representatives will refer to this manual when servicing the 2216 on site. The person using this manual should be:

- Trained to service the 2216.
- Familiar with the configuration and operation of the 2216.

Planning and Installation

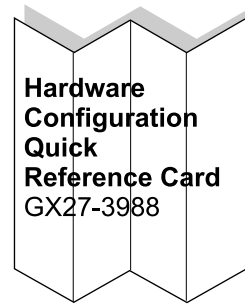
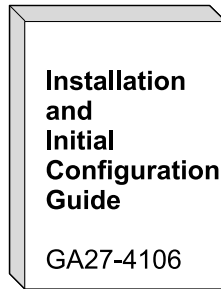

Configuration

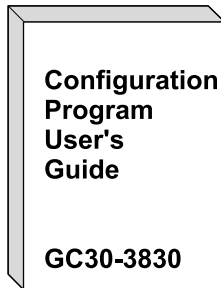

Diagnostics/Maintenance

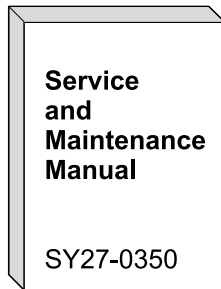

Operations and Network Administration

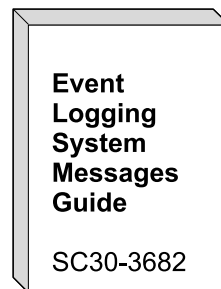
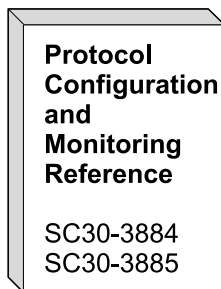
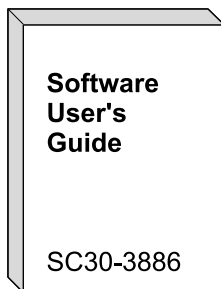

2216 Library Overview

The following list shows the publications in the IBM 2216 library, arranged according to tasks.

Table 0-1. Hardcopy Publications that Are Shipped with the 2216

These documents are shipped in hardcopy and are also contained on the 2216 CD-ROM, SK2T-0405.

Planning

GA27-4105 *2216 Nways Multiaccess Connector Introduction and Planning Guide*

This book explains how to prepare for installation, select the hardware that you want to purchase, and specifications for the hardware and software for your network. It also provides information on the management of routing networks.

Installation

GA27-4106 *2216 Nways Multiaccess Connector Installation and Initial Configuration Guide*

This booklet explains how to install the IBM 2216 and verify its installation.

GX27-3988 *2216 Nways Multiaccess Connector Hardware Configuration Quick Reference*

This reference card is used for entering and saving hardware configuration information used to determine the correct state of an IBM 2216.

Diagnostics and Maintenance

SY27-0350 *2216 Nways Multiaccess Connector Service and Maintenance Manual*

This book provides instructions for diagnosing problems with and repairing the IBM 2216.

Safety

SD21-0030 *Caution: Safety Information—Read This First*

This book provides translations of caution and danger notices applicable to the installation and maintenance of a IBM 2216.

Operations and Network Management

The following list shows the books that support the Nways Multiprotocol Access Services program.

SC30-3886 *Nways Multiprotocol Access Services Software User's Guide*

This book explains how to:

- Configure, monitor, and use the Nways Multiprotocol Access Services software.
- Use the Nways Multiprotocol Access Services command-line router user interface to configure and monitor the network interfaces and link-layer protocols shipped with the IBM 2216.

SC30-3884 *Nways Multiprotocol Access Services Protocol Configuration and Monitoring Reference, Volume 1*

SC30-3885 *Nways Multiprotocol Access Services Protocol Configuration and Monitoring Reference, Volume 2*

These books describe how to access and use the Nways Multiprotocol Access Services command-line user interface to configure and monitor the routing protocol software shipped with the product.

They include information about each of the protocols that the device supports.

SC30-3682 *Nways Event Logging System Messages Guide*

This book contains a listing of the error codes that can occur, along with descriptions and recommended actions to correct the errors.

Configuration

GC30-3830 *Configuration Program User's Guide*

This book discusses how to use the Nways Multiprotocol Access Services Configuration Program.

Visit our Web Sites

This IBM web page provides product information:

<http://www.networking.ibm.com/216/216prod.html>

Information, Updates, and Corrections

This page provides information on engineering changes, clarifications, and fixes that were implemented after the books were printed:

<http://www.networking.ibm.com/216/216lib.html#relnts>

Summary of Changes

The changes to the IBM 2216 library and product since the first edition of the product information are indicated by a vertical line (|) to the left of the change, and consist of:

- Library Improvements
 - Content changes to the planning guide, the installation guide, and the maintenance manual (along with changes to the book titles)
 - Clarifications and corrections
- Product enhancements :
 - Hardware Updates
 - These adapters / Line Interface Couplers (LICs):
 - LIC 286, FDDI
 - LIC 289, HSSI
 - LIC 288, 10/100 Mbps Ethernet
 - LIC 287, ESCON Channel (from Release 1.1)
 - LIC 294 high-performance 155-Mbps ATM multimode fiber (MMF)
 - LIC 295 high-performance 155-Mbps ATM single-mode fiber (SMF)
 - System card (200-Mhz) with 64-MB base memory (and additional 64-MB memory option)
 - Software Updates
 - Protocol Enhancements:
 - IP
 - IPX
 - Bridging
 - APPN
 - Appletalk
 - DLSw
 - Infrastructure Enhancements
 - Serviceability
 - Server Enhancements
 - Network Management
 - Connectivity Enhancements
 - PPP
 - Frame Relay
 - X.25
 - LAN
 - WAN
 - ISDN
 - Channel (ESCON)
 - ATM Enhancements
 - ESCON Channel Adapter Enhancements:
 - Support for IP over MPC+ to TCP/IP in the Host.
 - Support for IP over MPC+ to HPDT UDP in the Host.

Chapter 1. Problem Determination

Note: The 2216 service representative will need to have the diagnostics run remotely by the operator at a station connected via the modem. Alternatively, the servicer can run the diagnostics on site through an ASCII terminal connected directly to the 2216.

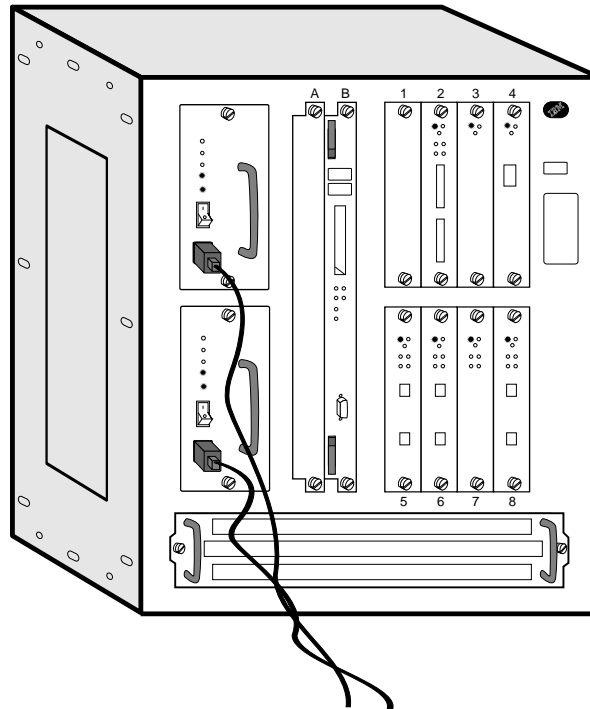

2216 Power Supply

The power supply panel contains:

- The power switch, which is used to power ON or OFF the 2216
- The Overcurrent Reset switch, which resets all current-limit circuits for the +12 V and -48 V outputs at the same time.

System Card LEDs

After power-on-reset (POR), the green and yellow LEDs will remain on until successful completion of the power on tests (which will be under 2 minutes). The green LED will begin blinking, which indicates that the code is being loaded into memory. The green LED will be switched on to indicate that the system code is operational.

Note: If the 2216 is waiting for the power-on password, the green LED is off. If you do not have the console attached, you will not know that the system is waiting. Looking at the LEDs may lead you to believe that you have a hardware problem.

LED Indicators

The IBM 2216 has a number of light-emitting diodes (LEDs) that indicate how the unit is functioning.

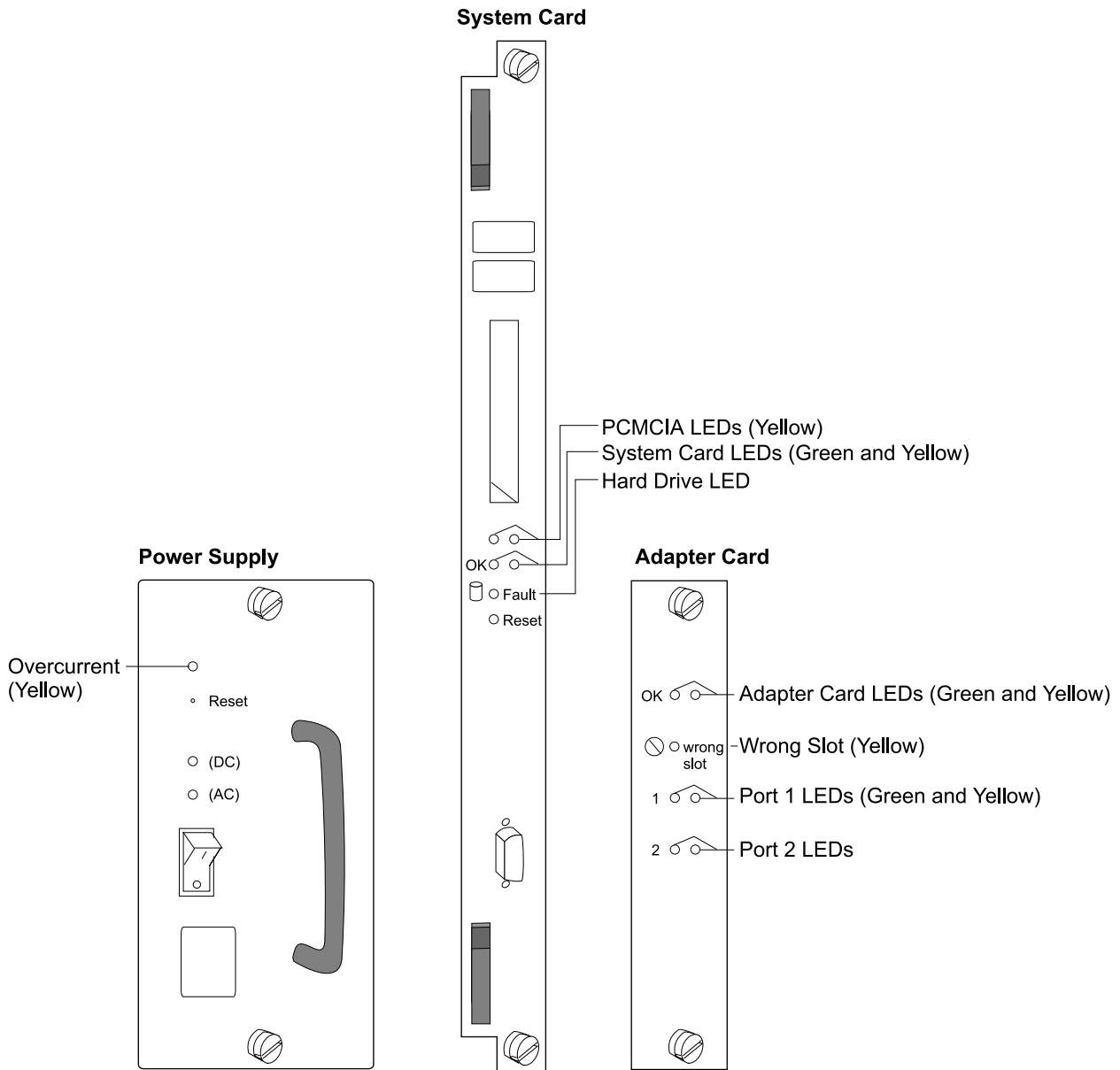

Figure 1-1. Power Supply, System Card, and Adapter Card LEDs

Power Supply Status

LEDs	Meaning
Yellow (Overcurrent)	On - There is an overcurrent condition with the -48 V to one or more of the adapters (slots 1–8) or the +12 V to the fan tray.
Green DC	On - +5 V, +12 V, and -48 V are OK.
Green AC	On - AC source voltage is present and within tolerance.

System Card Status

LEDs	Meaning
PCMCIA 1 or PCMCIA 2 (Yellow)	On - PCMCIA device has a fault, is not installed, or is not seated correctly. Off - Device passed self-tests
OK (Green)	On - Card hardware is operating normally. Blinking - Loading from hard file
OK (Yellow)	On - Card hardware has a fault.
Fault Hard Drive (Yellow)	On - Hard drive has failed.

Adapter Card Status

LEDs	Meaning
OK (Green)	On - Adapter is operational.
OK (Yellow)	On - Adapter has a fault.
Wrong slot (Yellow)	On - Adapter is in the wrong slot. The wrong slot LED is ON only when an adapter that is plugged into the 2216 violates the plugging rules described in Appendix E, "Adapter Plugging Defaults" on page E-1.
Green port ¹	On - Port is operating normally (enabled and configured). Off - Port is not configured or is disabled. For the ESCON adapter: Blinking - The optical power measurement test is running.
Yellow port ¹	On - One or more ports has a hardware fault. Blinking - One or more ports has a port I/O or network failure. Use the Maintenance Analysis Procedures (MAPs) to isolate. Off - No problem detected.

Important Phone Numbers

Contact Name	Telephone Number
System Administrator:	
Service Representative:	

¹ The port LEDs of the multiport WAN adapters (FC 2282, FC 2291, and FC 2292) reflect the status of one or more of the ports.

Troubleshooting

Both hardware and software (operational code and configuration) problems can affect the IBM 2216. Light-emitting diodes (LEDs), diagnostic programs, and error messages provide information needed for problem determination. This manual is chiefly concerned with diagnosing and correcting hardware problems. Chapter 3, "Accessing the 2216" on page 3-1 has information about accessing the IBM 2216.

Diagnosing Hardware Problems

Generally, errors that occur **before** the operational code is loaded are hardware-related. Light-emitting diodes (LEDs) on the front of the IBM 2216 indicate how the hardware components are functioning.

Go to "LED Indicators" on page 1-2 for LED status and indicators for the IBM 2216. See "2216 FRU Exchange" on page 2-3 for information on removal and replacement procedures for field-replaceable units (FRUs).

See Chapter 4, "Using 2216 Firmware" or Chapter 5, "Using Operational Diagnostics" (depending on how you are connected to the IBM 2216) to run hardware diagnostics **before** the IBM 2216 has been configured.

Diagnosing Operational Code and Configuration Problems

Generally, errors that occur **after** the operational code is loaded indicate problems with the operational code or configuration file.

Error codes and corrective action are described in the *Event Logging System Messages Guide*.

See Chapter 4, "Using 2216 Firmware" or Chapter 5, "Using Operational Diagnostics" to run diagnostics **after** operational code and configuration files have been loaded.

MAP 0600: 2216 Basic Verification

001

- On the 2216 power supply, switch the power ON.
- Within 2 minutes, check the status of the LEDs on the front of the 2216.
- If the service terminal display is unreadable refer to “MAP 0610: Service Terminal Display Unreadable” on page 1-10.

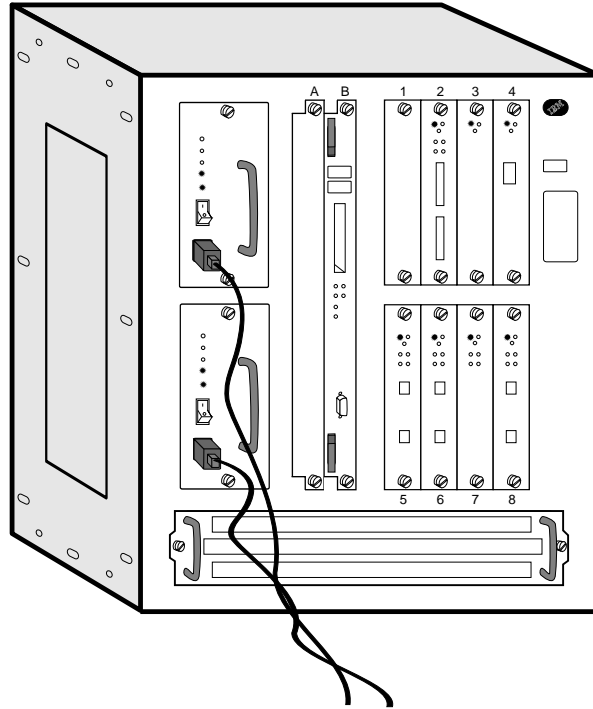

Table 1-1 shows the desired status of the LEDs. The LEDs on the 2216 should have the following status when operating normally.

<i>Table 1-1. Machine LEDs When Operational</i>	
LED	Status
Power supply overcurrent yellow	OFF
Power supply DC indicator	ON
Power supply AC indicator	ON
System card PCMCIA (with device installed) Port 1 yellow	OFF
System card PCMCIA (with device installed) Port 2 yellow	OFF
System card green	ON
System card yellow	OFF
All adapter green LEDs	ON
All adapter yellow LEDs	OFF
Wrong slot LED	OFF
All I/O port green LEDs	ON
All I/O port yellow LEDs	OFF

Table 1-2 shows messages that may appear at the operator console attached to the IBM 2216 to indicate a problem.

<i>Table 1-2. Network Management Console Messages</i>	
Message	Comments
Fan motor speed	Replace fan assembly
2216 is overheating	Check for: <ul style="list-style-type: none"> • Room air conditioning • Obstruction of airflow • Fan motor problem
Memory error with DIMM slot y	Replace the system card. See "Exchanging the System Card" on page 2-5.

Are all LEDs OK?

Yes No

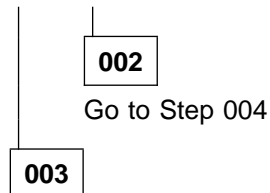

The 2216 should be functioning.

004

In Table 1-3, select the symptom that fits your situation.

<i>Table 1-3. LED and symptoms</i>	
LED Status	Action
AC indicator LED on a power supply is OFF.	Step 005
DC indicator LED on a power supply is OFF and the AC indicator is ON.	Step 008 on page 1-7
Overcurrent Indicator LED on power supply is ON.	Step 011 on page 1-7
Adapter yellow fault indicator LED is ON (adapter is failing).	Step 018 on page 1-8
Adapter Yellow Wrong Slot LED is ON.	Step 021 on page 1-8
I/O port Yellow indicator is ON or BLINKING.	Step 022 on page 1-8
Yellow indicator on system card is ON	Step 025 on page 1-9
PCMCIA yellow indicator on system card is ON	Step 026 on page 1-9

005

You are at this step because the AC indicator on a power supply is OFF. Perform the following tests:

1. On the suspected power supply, check that:
 - The power cable is correctly connected to the ac power outlet and to the front of the power supply.
 - The power supply is correctly seated in the unit.
2. With a multimeter, check that there is power at the power outlet.
3. With the power cable connected to the power outlet, use a multimeter to verify that the power cable is good.

If you detect no problems with any of the above, replace the power supply. See “Exchanging a Power Supply” on page 2-4.

Is the AC indicator LED now ON?

Yes No

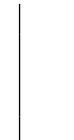

006

Call your support center for assistance.

007

Restart the verification procedure. Go to Step 001 on page 1-5.

008

The DC indicator on a power supply is OFF. Replace the power supply. (See “Exchanging a Power Supply” on page 2-4.) Is the problem corrected?

Yes No

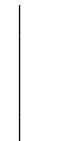

009

Contact your support center for assistance.

010

Restart the verification procedure. Go to Step 001 on page 1-5.

011

The Overcurrent LED on a power supply is ON. Are all adapter yellow fault LEDs OFF?

Yes No

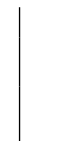

012

Remove the adapter with a yellow fault LED ON, and then press Reset on the power supply. Is the Overcurrent LED now OFF?

Yes No

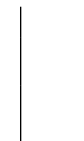

013

Replace the power supply. Restart the verification procedure. Go to Step 001 on page 1-5.

014

(Step **014** continues)

014 (continued)

Replace the adapter. (See “Exchanging an Adapter” on page 2-14.) Restart the verification procedure. Go to Step 001 on page 1-5.

015

The problem may be with the fan tray. Remove it (see “Exchanging the Fan Tray” on page 2-13) and press Reset. Does this correct the problem?

Yes No

016

Reinstall the fan tray. Contact your support center.

017

Replace the fan tray and restart the verification procedure. Go to Step 001 on page 1-5.

018

A yellow fault indicator LED on an adapter is ON. Replace the adapter. (See “Exchanging an Adapter” on page 2-14.) Does this correct the problem?

Yes No

019

Contact your support center.

020

Restart the verification procedure. Go to Step 001 on page 1-5.

021

The **yellow** Wrong Slot LED indicator on an adapter is ON.

- If adapter LIC 280 or LIC 281 is in slot 3, then slot 4 must be empty.
- If adapter LIC 280 or LIC 281 is in slot 4, then slot 3 must be empty.
- If adapter LIC 280 or LIC 281 is in slot 7, then slot 8 must be empty.
- If adapter LIC 280 or LIC 281 is in slot 8, then slot 7 must be empty.

The Wrong Slot LED indicates that one of the above restrictions is not being observed. Relocate the adapter or adapters in slots 3, 4, 7, or 8 accordingly. Restart the verification procedure. Go to Step 001 on page 1-5.

022

A yellow LED indicator for an I/O port is ON or BLINKING. Is the yellow LED indicator BLINKING?

Yes No

023

I/O port LED ON - The adapter is defective. Replace it. (See “Exchanging an Adapter” on page 2-14.) Restart the verification procedure. Go to Step 001 on page 1-5.

024

I/O port LED BLINKING -

There is a problem with the adapter, the cable, the network, or the adapter software configuration is wrong.

Run an external wrap test on the I/O port. You must install an external wrap block (plug) prior to the test. (See "Wrap Test Plugs" on page 1-14 for the correct wrap plug.) See "Using the Command Line Interface Operational Diagnostics" on page 5-2 to run the diagnostics.

1. If the wrap test is successful, suspect the cable, the network, or that the adapter software configuration is wrong. Correct any problem that you find. Restart the verification procedure. Go to Step 001 on page 1-5.
2. If you suspect a problem with the ESCON adapter, run the list test (see page 5-12).

025

A yellow LED on the system card is ON. Is the Hard Drive LED ON?

Yes No

026

Is a PCMCIA Slot 1 or 2 LED ON?

Yes No

027

If system card fault yellow LED is on, the system card is defective. Replace it. See "Exchanging the System Card" on page 2-5. Restart the verification procedure. Go to Step 001 on page 1-5.

028

- The LED will be ON if there is no device plugged into the slot
- If a PCMCIA device is plugged into the slot and the LED is ON, reseal the PCMCIA device and press the **Reset** on the System Card.
- If the LED is still ON replace the PCMCIA device.

029

There is a hard drive failure. Replace the hard drive. See "Exchanging the Hard Drive on the System Card" on page 2-8. Restart the verification procedure. Go to Step 001 on page 1-5.

MAP 0610: Service Terminal Display Unreadable

Symptom Explanation	Conditions That Could Cause This Symptom
While you are diagnosing a problem, a terminal attached to the service port of the 2216 displays random characters instead of readable text.	<ul style="list-style-type: none"> • Incorrect configuration setting of the terminal or 2216 service port. • Incorrect terminal/device (ac) grounds. • Defective, incorrectly shielded, or incorrectly grounded EIA 232 cable between the terminal and the 2216. • Defective terminal or terminal emulator. • High ambient electromagnetic interference (EMI) levels. • Power line disturbances. • Defective 2216 system board.

001

Does the 2216 go to the active state within 2 minutes of resetting or powering on?

(Active state is indicated by the green system LED on and the yellow system LED off.)

Yes No

|

|

002

Go to Step 001 on page 1-5

003

Go to Step 004

004

– Press the service terminal break key sequence and press **Enter**.

You should try this a number of times before proceeding.

A typical terminal break key sequence is **Alt-b**.

– Press **Ctrl-p** at the service terminal.

Is a readable message displayed on the service terminal?

Yes No

|

|

005

– Go to Step 007 on page 1-11

006

– Go to Step 010 on page 1-11

007

- Press **Reset** and wait for the system green (OK) and yellow LEDs to start blinking or the system green (OK) to come on and the yellow LED to be blinking.
- Press the service terminal break key sequence and press **Enter**.
- Press **Ctrl-c** at the service terminal.

The terminal displays the > prompt.

- Enter **uc** at the prompt.

The 2216 displays the hardware configuration. The first line shows the autobaud speed and the configured service port baud rate, if they are different.

Are different autobaud and configured speeds displayed?

Yes No

008

- Go to Step 010.

009

- Set the terminal to the configured console baud rate displayed.
- Press the service terminal break key sequence and press **Enter**.

This action causes the 2216 to autobaud.

- Enter **Ctrl-c**.

The > prompt should be displayed. If the console baud rate is satisfactory, you can reboot the 2216 and the terminal will work. If the console baud rate is unsatisfactory and you want to change the rate:

1. Enter **bc** at the > prompt and select an IBD boot module.
2. Wait for the **Config (only)>** prompt to be displayed.
3. Enter **set baudrate 0** at the **Config (only)>** prompt.
4. Set the terminal to the desired baud rate.
5. Press the terminal break key sequence and press **Enter** to force the 2216 to autobaud to the new terminal speed.

Note: When using a terminal emulator, you may have to stop and restart the emulator when switching speeds for the emulator to display correctly.

- Continue at Step 010.
-

010

The terminal should now operate correctly and the new terminal speed has been saved.

(Step **010** continues)

010 (continued)

Is the terminal functioning correctly?

Yes No

011

– Go to Step 013

012

– Go to Step 024 on page 1-13

013

Is the terminal or the 2216 grounded correctly?

Yes No

014

Ground the device correctly. Go to Step 001 on page 1-5.

015

Is the EIA 232 cable between the terminal and the 2216 grounded correctly and shielded?

Yes No

016

Ground or shield the cable correctly or replace the cable. Go to Step 001 on page 1-5.

017

Is the terminal or the terminal emulator functioning correctly?

Yes No

018

Replace the terminal or the terminal emulator. Go to Step 001 on page 1-5.

019

Is the 2216 in an area with high ambient electromagnetic interference?

Yes No

020

(Step 020 continues)

020 (continued)

Are there power line disturbances?

Yes **No**

021

The 2216 system board is defective.

Replace the system board. Go to Step 001 on page 1-5.

022

Install an uninterruptible power supply to minimize the effects of the power fluctuations. Go to Step 001 on page 1-5.

023

Move the 2216 to a more isolated area. Go to Step 001 on page 1-5.

024

Go to Step 001 on page 1-5.

Service Kit—Feature Code 2505 (PN 85H5541)

The optional service kit provides wrap plugs for all IBM 2216 interfaces.

The wrap plugs cannot be purchased individually. You must purchase the entire kit.

Wrap Test Plugs

Table 1-4. IBM 2216 Adapter Wrap Plugs

Adapter	FRU P/N	Feature Code	Description	Wrap Plugs
LIC 280	85H5543 & 02L1873	2280	2-Port Token-Ring	UTP 04H8210
LIC 281	85H5542 & 02L1872	2281	2-Port Ethernet	UTP 04H8210 BNC 02G7433
LIC 282	85H4872	2282	8-Port EIA 232	CRD 68F7208 CBL 33F8985
LIC 283	85H4882 & 02I2065	2283	1-Port ISDN Pri (T1)	57G8097
LIC 284	85H4894	2284	1-Port 155-Mbps (MMF ATM)	16G5609
LIC 286	86H0967	2286	1-Port FDDI	two - 16G5609
LIC 287	85H4878	2287	1-Port ESCON Channel	5605670 fiber-optic jumper cable 14F3797
LIC 288	86H1005	2288	1 Port 10/100-Mbps Ethernet	21H4811
LIC 289	85H9703	2289	1 Port HSSI	86H0974 for Adapter 86H0973 for Cable
LIC 290	85H4874	2290	6-Port V.35/V.36	CRD 72F0168 V.35 BRICK 72F0167 V.36 CBL 73H2508
LIC 291	85H4876	2291	8-Port X.21	CRD 06H3357 CBL 52G3378
LIC 292	85H4884 & 02L2066	2292	1-Port ISDN Pri (E1)	57G8097
LIC 293	85H6834	2293	1-Port 155-Mbps (SMF ATM)	16G5609
LIC 294	86H0986	2294	1-Port 155-Mbps (MMF ATM)	16G5609
LIC 295	86H0993	2295	1-Port 155-Mbps (SMF ATM)	16G5609

LIC 282, LIC 290, and LIC 291 External Wraps

Figure 1-2 and Figure 1-3 on page 1-16 show the locations for the wrap plug usage for LICs with multiple wrap plugs.

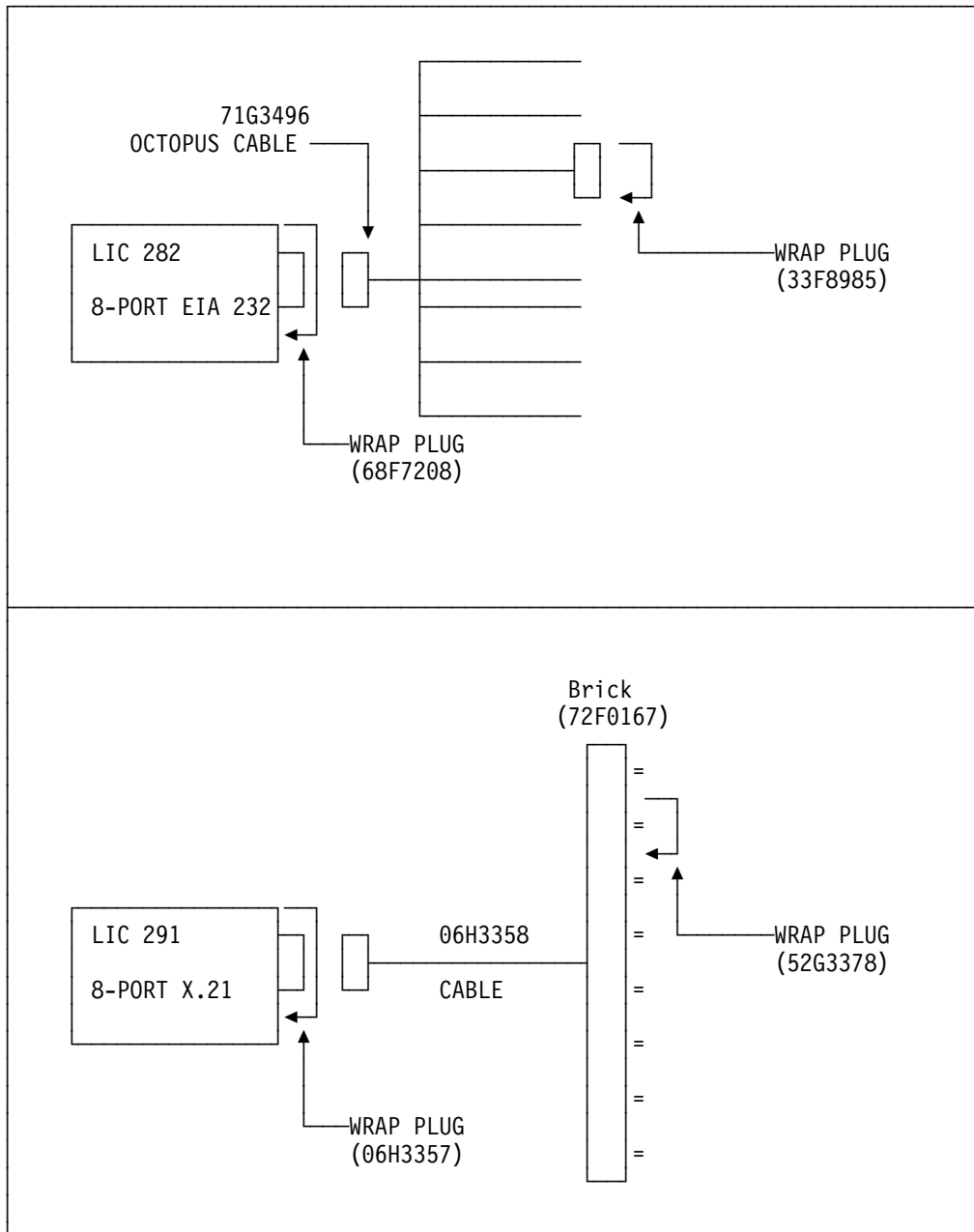

Figure 1-2. LIC 282 and LIC 291 Wrap Support

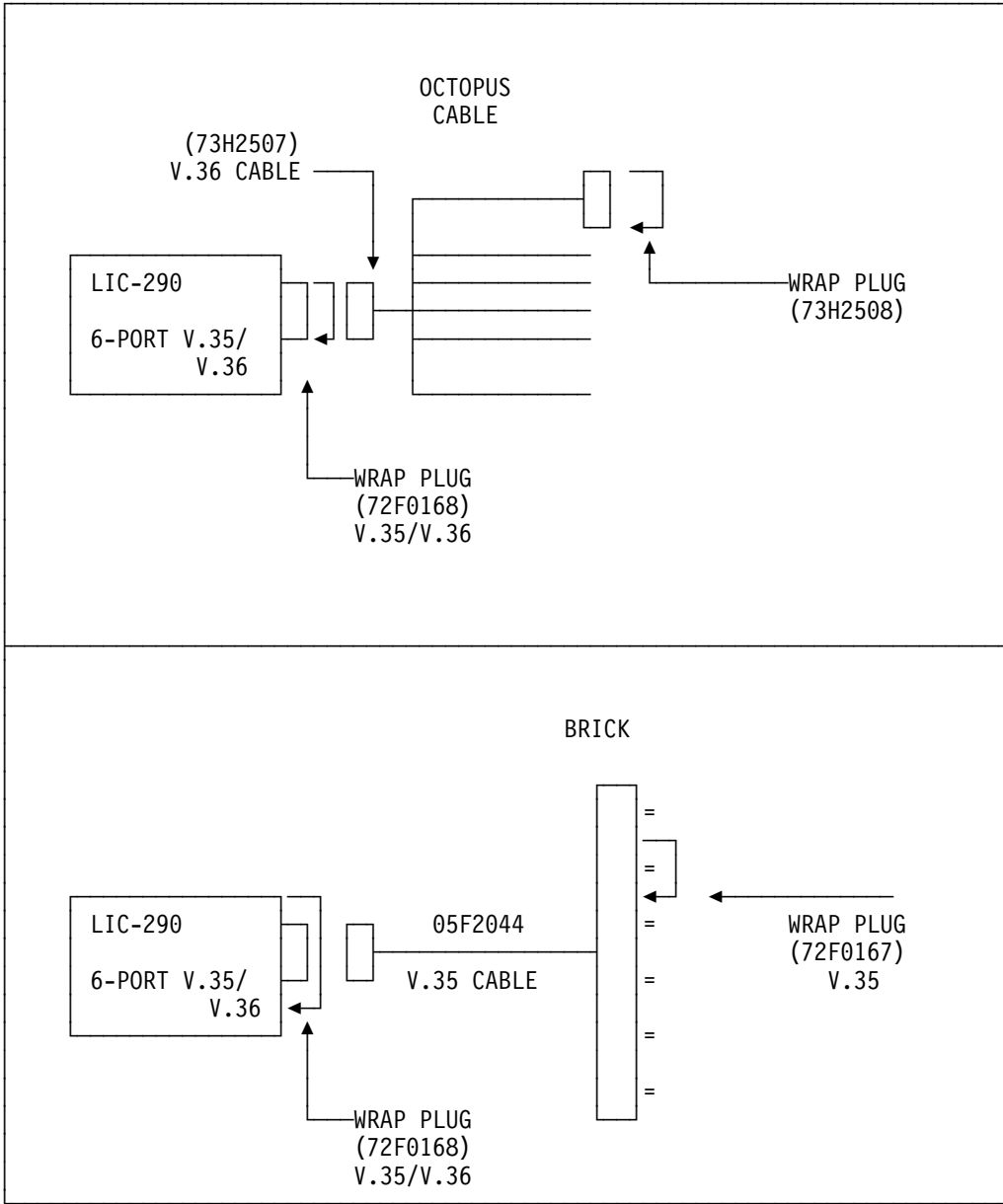

Figure 1-3. LIC 290 Wrap Support

Chapter 2. Removal and Replacement Procedures

This chapter provides the following information on removal and replacement procedures:

- Preparatory information that applies to all the removal and replacement procedures (see “Before You Start”).
- Descriptions of the individual FRU removal and replacement procedures (see “2216 FRU Exchange” on page 2-3).

For an overall perspective on the FRUs and their positioning relative to each other and the chassis, see Appendix B, “Parts Listing” on page B-1.

Before You Start

Before you begin any removal or replacement activity, review the list of equipment you will need, read the common safety precautions and then proceed.

Equipment You Need

You need the following equipment to remove and replace the FRUs in the IBM 2216

- 7-mm nut driver
- 5/32-inch nut driver
- Flat-blade screwdriver
- Screw starter (optional)

Safety Precautions

DANGER

To avoid a shock hazard, do not connect or disconnect any cables or perform installation, maintenance, or reconfiguration of this product during an electrical storm.

Disconnecting the Power Cord

Note: Disconnecting the power cord will disrupt users in your network. Consult the network administrator before disconnecting the power cord.

Disconnect the power cord from the ac power outlet and then from the IBM 2216.

Where to Go Next

If you are replacing the power cord, continue with “Reconnecting the Power Cord.”

Reconnecting the Power Cord

DANGER

To avoid shock hazard:

- The power cord must be connected to a properly wired and grounded receptacle.
- Any equipment to which this product will be attached must also be connected to properly wired receptacles.

Connect the power cord to the IBM 2216 and then to the ac power outlet.

2216 FRU Exchange

Important

The system card and a power supply in a 2216 with a single power supply are **not** hot pluggable. This means that you must switch off power to the adapter when replacing either of them. Other FRUs are hot pluggable and can be exchanged without powering OFF the 2216, although the adapter or other FRU must be reset before new configurations can take effect. Follow carefully the procedure described.

Before removing an adapter, be sure that the corresponding resource has been **disabled** by the operator at the operator console.

Each time you change a FRU, carefully record its location and check that the attached cables are correctly labeled and reconnected.

In Table 2-1, find the FRU you want to exchange and go to the procedure indicated.

FRU Name	Go to
Power supply	"Exchanging a Power Supply" on page 2-4
System card	"Exchanging the System Card" on page 2-5
Hard drive	"Exchanging the Hard Drive on the System Card" on page 2-8
DIMM	"Exchanging the Memory on the System Card" on page 2-11
Fan tray	"Exchanging the Fan Tray" on page 2-13
Adapter type xxx	"Exchanging an Adapter" on page 2-14
Backplane	"Exchanging the Backplane" on page 2-18

Exchanging a Power Supply

Attention: A power supply is hot pluggable if an optional load-sharing power supply is also installed.

- 1** Switch off the power supply.
- 2** Unplug the power cord.
- 3** Remove the power supply by loosening the screws at the top and bottom and pulling the handle.

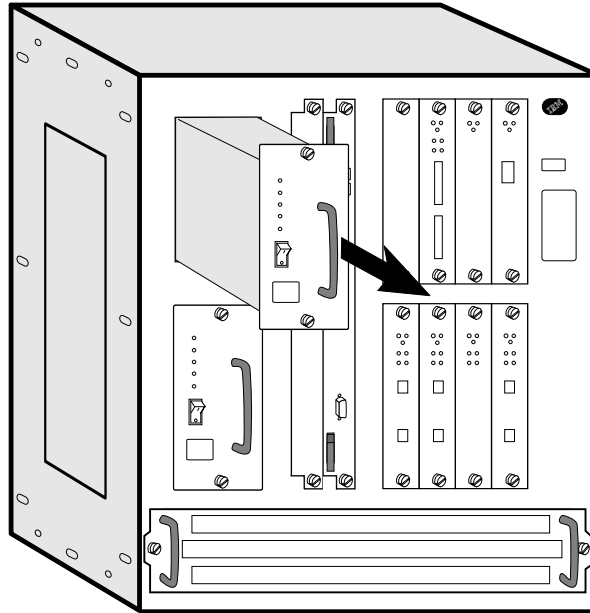

- 4** Install the new power supply. The power supply will slide into place on metal rails in the unit.
- 5** Attach the power cord.
- 6** Switch on the power.
- 7** Verify the LEDs. See "LED Indicators" on page 1-2.
- 8** Notify the network administrator that you are finished repairing the 2216.

Exchanging the System Card

Attention:

1. The system card is *not* hot pluggable.
2. You will remove and retain the hard file from the old system card. The hard file that comes with the new system card is *blank*.
3. Make note of the part number of your system card. The old system cards (part number 75H5081 or 85H7916) supported two 32-MB DIMMs (64 MB) of memory, whereas the redesigned system cards supports two 64-MB DIMMs (128 MB) of memory.
 - If you replace the old system (part number 75H5081 or 85H7916) card with the new card, you need to upgrade the firmware to allow the use of the new memory DIMMs.

- 1** Switch off each power supply.
- 2** Label the cables on the system card. Unplug the cables and the PCMCIA modem (or other PCMCIA cards).
- 3** Loosen thumbscrews on the system card.
- 4** Remove the defective system card.

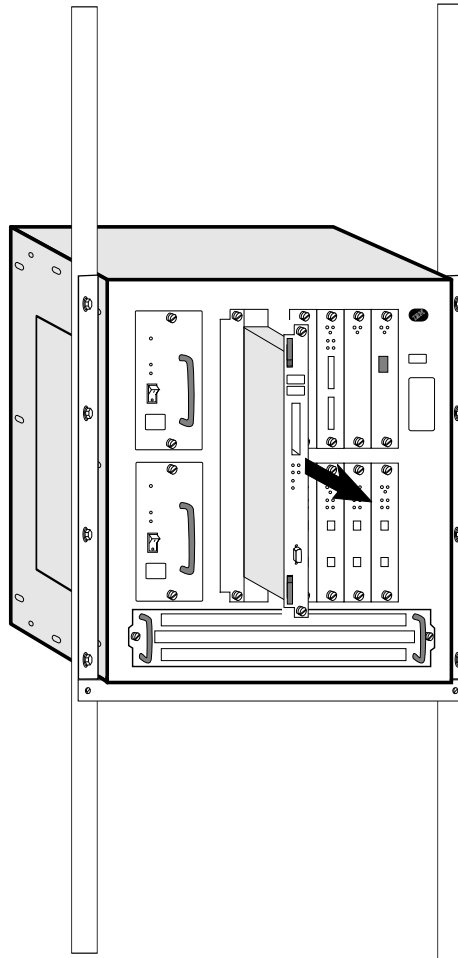

- 5** Remove the hard drive from the defective system card and install it on a new system card (see “Exchanging the Hard Drive on the System Card” on page 2-8). Return the hard drive that came with the new system card with the defective system card. The hard file that comes with the new system card is blank.
- 6** If you have the Release 2 system card (PN 85H9682) with two 64-MB DIMMs (128 MB) of memory on the faulty system card, remove one of the DIMMs from the faulty system card (“Exchanging the Memory on the System Card” on page 2-11) and put it on the new system card.
- 7** Install the new system card. Make sure the card is aligned with the plastic grooves and then slide it in until it is flush with the box.

Hold the locking latches so that they are perpendicular to the face of the system card. With the card in full contact with the rear of the IBM 2216, press the locking latches into the system card.
- 8** Tighten the thumbscrews on the face of the adapter card clockwise.
- 9** Plug the cables into the system card.
- 10** Plug the PCMCIA modem into the new system card.
- 11** Power on and verify the LEDs. See “LED Indicators” on page 1-2.

- 12** Write the box serial number into the Vital Product Data on the new system card. Go into the firmware (see "The Firmware Interface" on page F-1) and follow the procedures for using the Utilities option.
 - a. Under Utilities, select option 9 "View or Set Vital Product Data"
 - b. Select slot B
 - c. Select the "Hardware Vital Product Data" option
 - d. Type in the box serial number.

- 13** Notify the network administrator that you are finished repairing the 2216.

Exchanging the Hard Drive on the System Card

- 1 Remove the system card as described in steps 1 through 4 in “Exchanging the System Card” on page 2-5.

Attention: In the following step, be sure to support the hard drive to avoid damaging the pins when the screws are removed.

- 2 Lay the system card on a soft non-conductive surface.
- 3 On the bottom of the system card, remove the four screws (with a screw starter) while holding the hard drive in place.

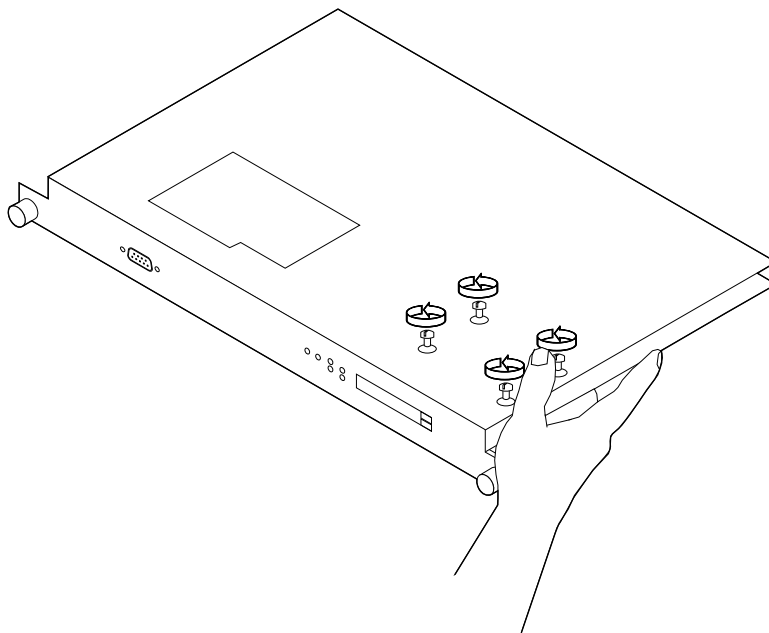

- 4 On the reverse side of the system card, disconnect the drive from the connector and lift it off the system card.

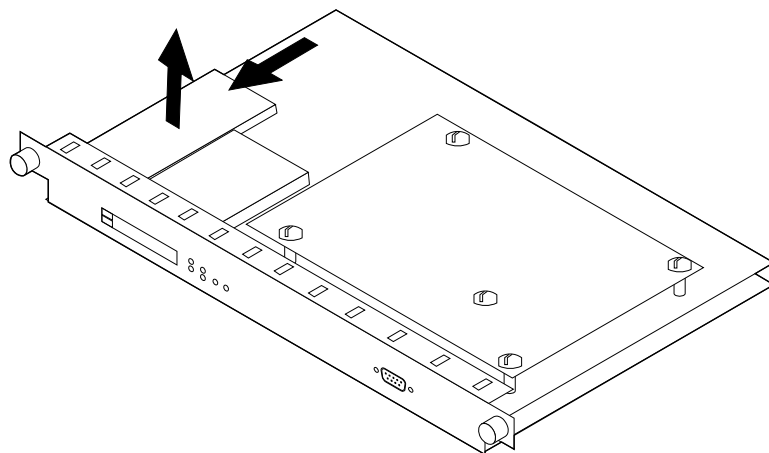

5 Center the new hard drive inside the lines on the system card.

Note: If you do not center the hard drive, the electrical pins on the hard drive will be visible next to the hard drive connector on the system card. Install the new hard drive by reversing steps 3 and 4 above. Be sure to support the hard drive while installing the screws.

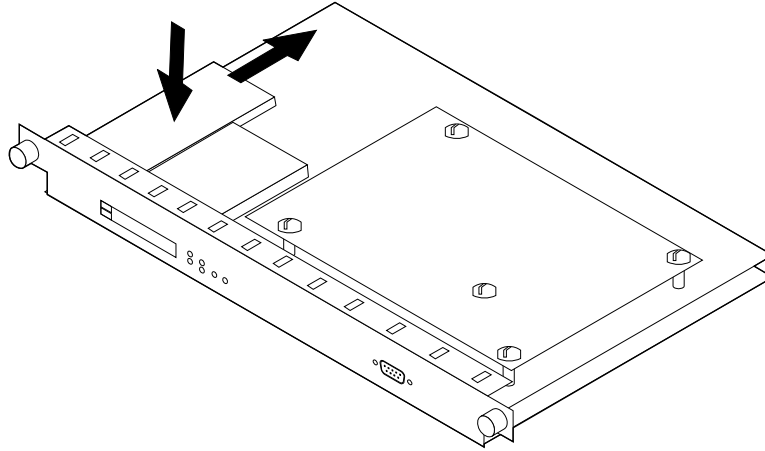

6 Reinstall the system card as described in “Exchanging the System Card” on page 2-5.

Installing Operational Software on the New Hard Drive

Note: This procedure should be performed by trained IBM service personnel. Customers who need this done should contact IBM service.

Follow these steps to install the operational software on the hard drive:

- 1** Restart the IBM 2216 in Attended mode or press **F1** (possibly several times) during the load sequence from a console. (You can also access the firmware from the command line interface. See the chapter entitled "Accessing the Firmware from the Command Line Interface" in the *2216 Software User's Guide* for additional information.) This will bring up the firmware System Management Services menu.
- 2** Select **Utilities**.
- 3** From the menu, select **Prepare Hard Disk** and press **Enter**.
 - If no errors occur, continue with step 4.
 - If error code 30002000 occurs during format, proceed as follows:
 - a. From the System Management Services menu, select **Select Device to Test**
 - b. Select **Test IDE devices**
 - c. Press the **F4** key for Parm Setup
 - d. Select **Run Interactive Test and Stop on Error**
 - e. Press **F6** to begin the tests
 - Attention** The next step formats the hard disk and destroys all data on the hard disk
 - f. Select **Format IDE device**, and press **Enter**
 - g. Return to step 3.
- 4** Reload the firmware to the hard disk using Xmodem (see "Updating System Firmware" on page 4-14).
- 5** The hard drive is now prepared to receive operational software files.
- 6** Select **Utilities** from the System Management Services menu
- 7** Select **Change Management** (see "Change Management" on page 4-21).
- 8** Use Xmodem to transfer the complete set of operational software files from a workstation to the IBM 2216 hard drive (see step 10 on page F-10). You transfer the files to banks within the IBM 2216. These banks represent the directories that you have just created.
- 9** After you have successfully transferred the operational software, go through the configuration procedures to enable the new software (see "Performing Change Management Operations" in the *Multiprotocol Access Services Software User's Guide*).

Exchanging the Memory on the System Card

The 2216 comes with a minimum of 64 MB (one dual inline memory module [DIMM]). There are slots for two DIMMs on the system card.

This procedure can be used for removing faulty DIMM modules or to install memory upgrades to your 2216.

- 1** Identify the faulty memory module. DIMM socket A is positioned closest to the edge of the system card.
- 2** Remove one or both of the DIMMs by pulling down the lever to the left. (Use your thumbnail or a small non-metallic device to gently move the spring latch away from the end of the DIMM.) The DIMM will automatically be pushed partially out of the slot.

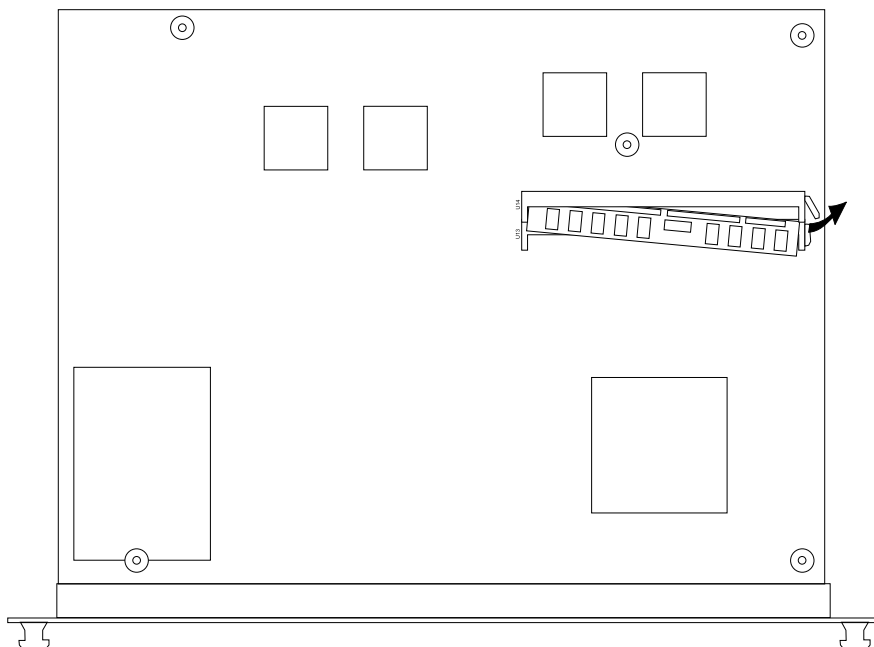

- 3** Gently slide the DIMM module out of its connector socket.
- 4** If you are installing **new** memory DIMMs, continue with the following procedure: (If you are replacing DIMMs that you previously removed, go to step 6 on page 2-12.)
 - a** Remove the DIMM, in its antistatic bag, from its shipping container.

Attention: Electrostatic discharge (ESD) can damage the static-sensitive devices on circuit boards. To avoid this kind of damage, use the following precautions:

 - Do not remove the DIMM until you are ready to insert it into the 2216.
 - Use correct grounding techniques when inspecting and installing the DIMM. Use a foot strap or grounding mat, or wear a grounded static discharge wrist strap, or touch a grounded rack or other source of ground before you handle the DIMM.
 - b** Remove the DIMM from the antistatic bag. Inspect it for damage. Always handle the DIMM by the ends (preferably grasp it between the middle finger and thumb; do not touch the components). If the DIMM appears to be damaged, return it to the antistatic bag and contact the supplier.

- 5** Locate the slot numbered U87 if you are installing one 64-MB DIMM, or locate the slot numbered U86 if you have two 64-MB DIMMs.
- 6** Insert the replacement DIMM into the appropriate slot. (Grasping the DIMM between the middle finger and thumb, place it connector edge down into the DIMM socket. Applying slight pressure to the top edge of the DIMM, move it forward until it is correctly aligned and snaps in place.)

The lever will snap back into place as the DIMM is fully inserted.

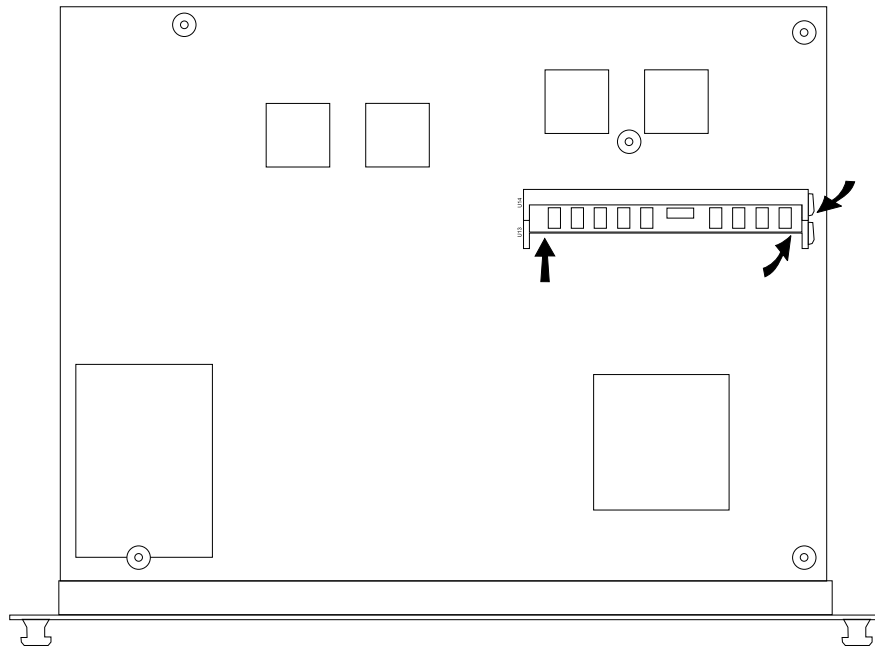

- 7** If your only task was to remove and replace or initially install a DIMM, you are ready to reinstall the system card. Go to "Exchanging the System Card" on page 2-5.

Exchanging the Fan Tray

Attention: The fan tray *is not* hot pluggable on 2216s that have a Release 1 system card (PN number 75H5081 or 85H7916). You must shut down the 2216 completely before replacing the fan tray. If the fan tray is removed, or if two or more fans fail, the box may shut down.

The fan tray is hot pluggable on 2216s that do not have the Release 1 system card (PN number 75H5081 or 85H7916); however, you must install the new tray within 3 minutes of removing the defective tray to prevent overheating the IBM 2216.

- 1 Loosen the two thumbscrews that secure the fan tray and remove the fan tray.

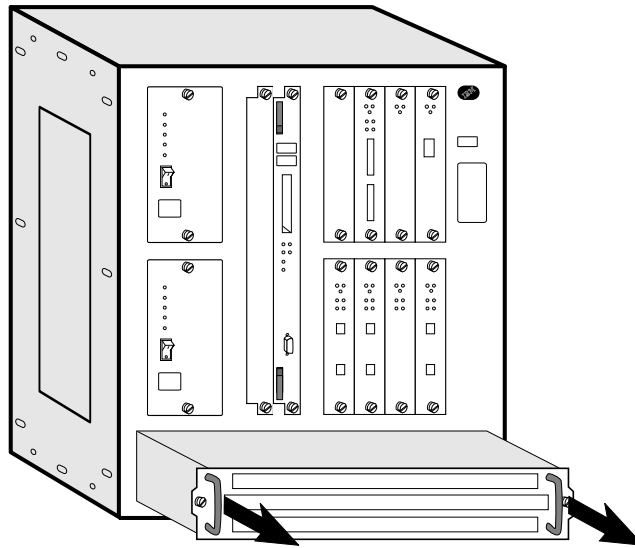

- 2 Slide the new fan tray in until the tabs on the back of the fan tray are in the slots. This aligns the connectors with the plugs.

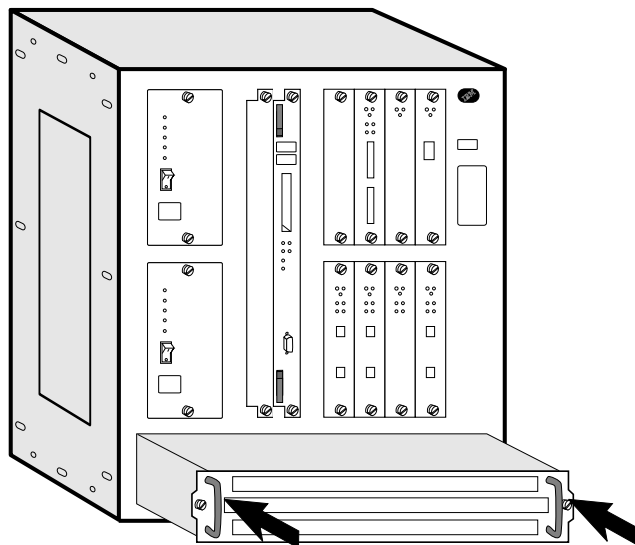

- 3 When the fan tray is flush with the box, tighten the two thumbscrews.

Exchanging an Adapter

Note: The adapter you replace must be of the same type as the original. Otherwise, you will need to reconfigure. See the *2216 Introduction and Planning Guide* and the *Multiprotocol Access Services Software User's Guide* .

1 Locate the adapter module to be replaced.

Attention:

- a. Adapters are hot pluggable, but you must disable all adapter ports before you remove cables. See "Suspend Traffic on an Adapter Port" on page F-7.
- b. If an adapter is removed prior to disabling the ports, a machine check can occur and the 2216 may become idle.
- c. If you are removing a serial adapter (EIA 232E/V.24, V.35/V.36, X.21, which are LICs 282, 290 and 291), you need to disable the WAN Reroute process before you remove the adapter. (See "Disabling Interfaces that Have WAN Reroute Enabled" on page F-8.)

2 Label the cables for correct reconnection.

3 Loosen the screws (if present) that secure the cable or cables.

4 Remove the cable or cables.

Attention: You must turn the adapter's thumbscrews simultaneously when unseating or seating the adapter during removal or installation. By doing so, you prevent stripping the thumbscrews. If you strip the thumbscrews, you may not be able to seat or reseal the adapter correctly.

5 Loosen the screws on the adapter.

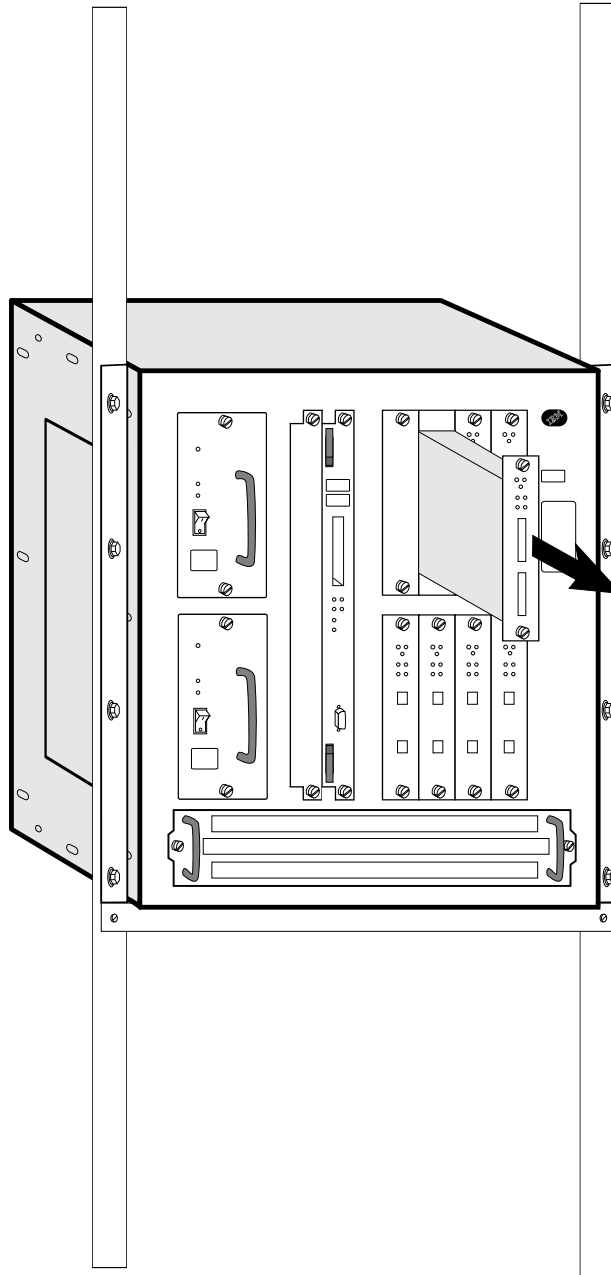

6 Remove the adapter from its location.

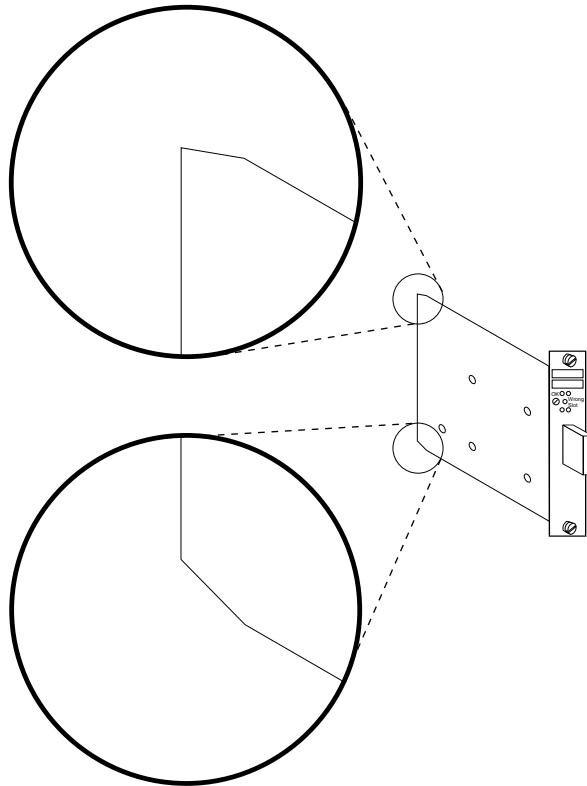

7 Notice the notches at the adapter card's angled corners and position them on the left as illustrated.

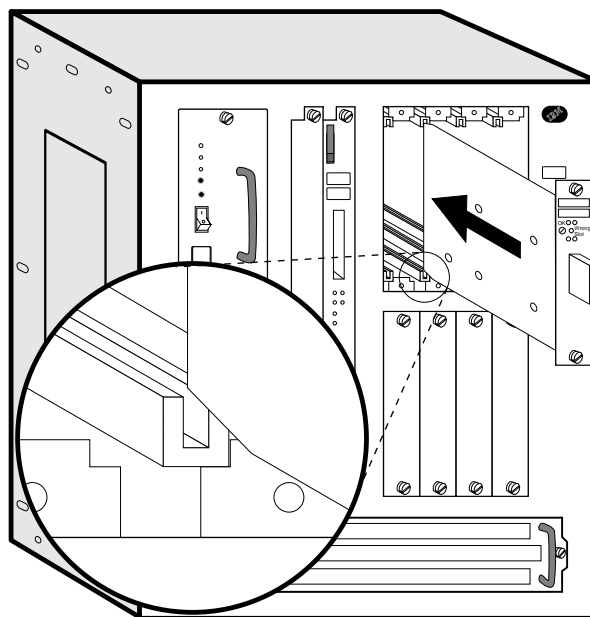

8 Carefully position the notches of the adapter card in the appropriate adapter slot's upper and lower rails. Then, guide the adapter forward on the rails as pictured.

9 Make sure the adapter card is aligned with the plastic grooves and then slide it in until the thumbscrews contact the frame.

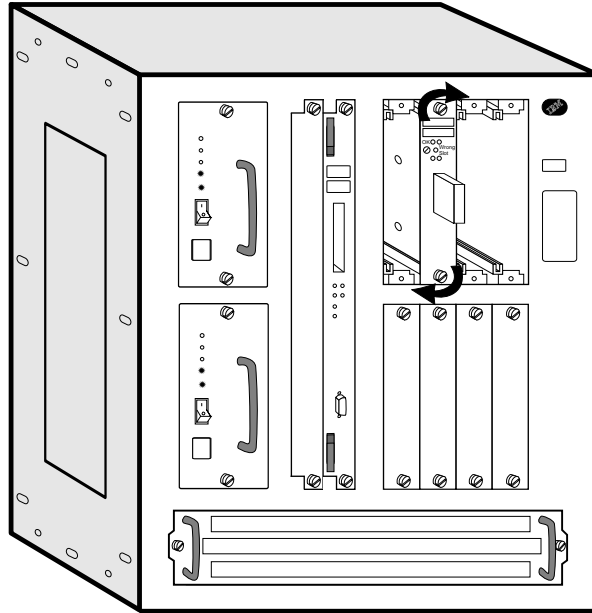

When the card makes full contact with the rear of the IBM 2216, press and simultaneously turn each thumbscrew on the face of the adapter card clockwise, **only** until the adapter is firmly seated.

- 10** Secure the module by tightening the screws.
- 11** Check that the green LED of the adapter comes ON and that the Wrong Slot LED is OFF. If not, check the adapter installation. If the problem persists call the support center. Otherwise, continue.
- 12** If you are replacing/inserting a serial adapter (EIA 232E/V.24, V.35/V.36, X.21, which are LICs 282, 290 and 291) and you went through the WAN Reroute disable procedure (“Disabling Interfaces that Have WAN Reroute Enabled” on page F-8), you need to enable the WAN Reroute process. (See “Enabling WAN Reroute after You Have Disabled it” on page F-9).
- 13** Replace the removed cable or cables, then tighten the cable screws (if present).
- 14** Re-enable all adapter ports. See “Resume Traffic on an Adapter Port” on page F-7.

Exchanging the Backplane

Note: If the 2216 is rack-mounted, this procedure requires two people to remove and install the 2216 in the rack.

- 1** Switch off each power supply.
- 2** Unplug the power cord from the power receptacle.
- 3** Label the cables with the adapters and ports they plug into. Unplug all the cables.
- 4** Make a note of the slot position of each card in the unit. If you have a filled-out *Hardware Configuration Quick Reference* card, this information should be already available. This card should be in the area on the underside of the IBM 2216 on the left.

5

CAUTION:

A fully populated IBM 2216 weighs about 43.1 kg (95 lb).

If the 2216 is rack-mounted continue with step 6; otherwise, go to step 11 on page 2-20.

6 Remove the:

- Power supplies (loosen the screws on each component and pull the handle).
- System card (see “Exchanging the System Card” on page 2-5).
- Adapters (see “Exchanging an Adapter” on page 2-14).
- Fan tray (see “Exchanging the Fan Tray” on page 2-13).

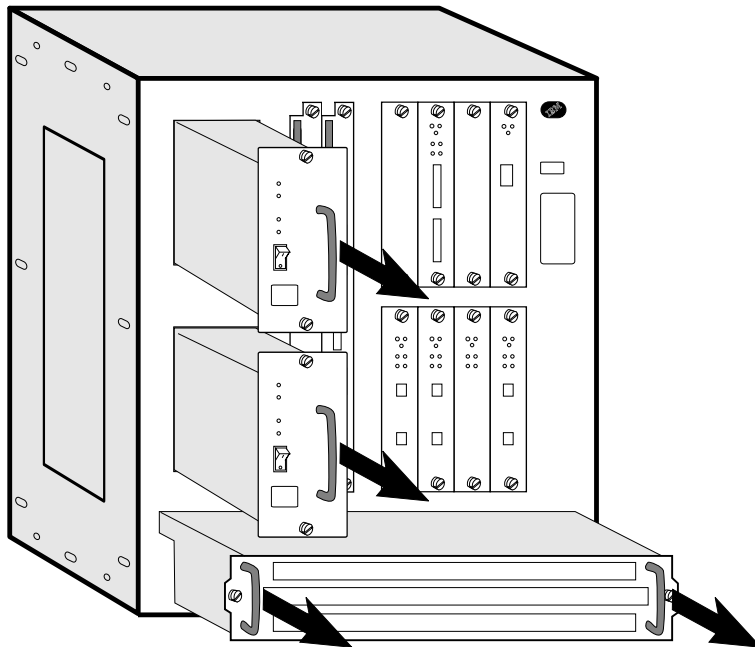

- 7** If the 2216 is installed in a rack, but not on a shelf, it is recommended that you install a shelf or the installation aid under the 2216 before removing the screws from the rack-mounting brackets.

8 Remove the screws from the rack-mounting brackets.

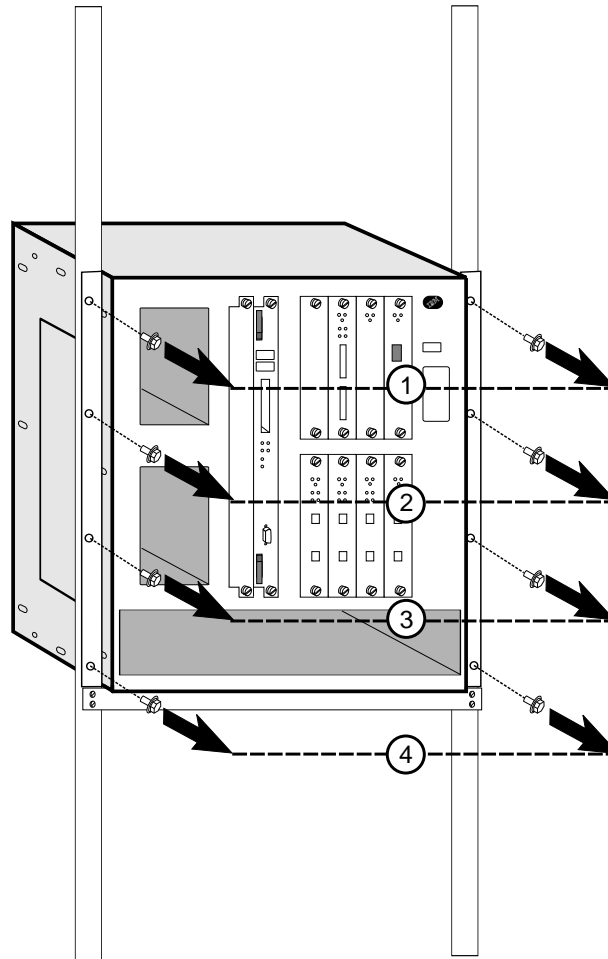

9 Hold the 2216 from the top of the back and bottom of the front, and then slide it forward out of the rack.

10 Place the 2216 on a table.

- 11** Remove the three screws near the top of the side panels.

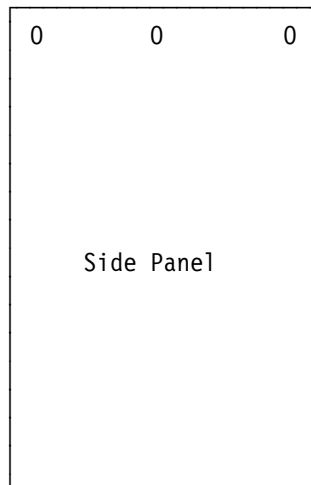

- 12** Remove the top panel. To do this, go to the rear of the 2216. Lift the top panel, and then slide the panel toward you.

- 13** On each side of the 2216, remove the three screws along the rear of the side panels of the 2216 that hold the backplane in place.

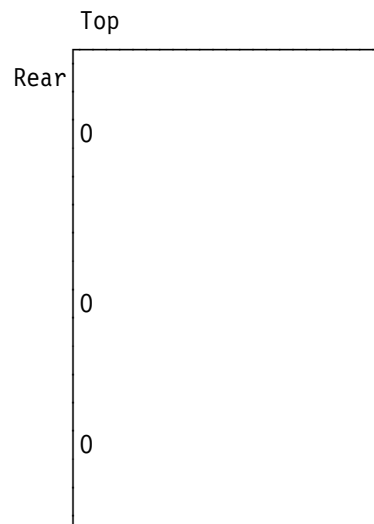

14 Remove the eight nuts and star washers located on the inside of the 2216.

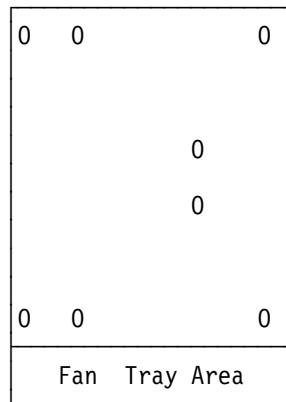

Relative locations of the nuts viewed from the front of the box

15 Hold the backplane by the finger holes and lift it straight out of the 2216.

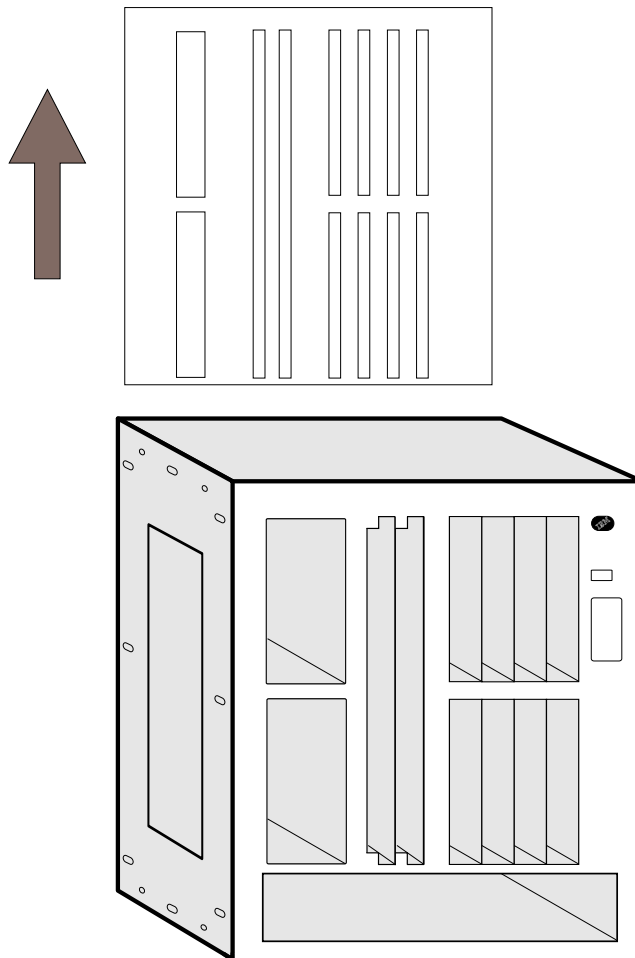

16 Hold the new backplane by the finger holes and lower it gently into the 2216.

17 Align the screw holes on the backplane with those on the sides of the box.

18 Loosely install the top two screws on each side of the 2216.

- 19** Reach inside the 2216, grasp the bottom middle of the backplane's plastic shield, and press it up and toward you until all the bulkhead screws protrude through the chassis.
- 20** Loosely insert the remaining screws on each side.
- 21** Install and tighten the eight nuts and star washers inside the 2216 that secure the backplane to the system.
- 22** Tighten the screws along the side of the box that hold the backplane in place.
- 23** Replace the top of the unit.
 - a** Align the five tabs on the top panel with the slots on the top front of the 2216.
 - b** Lower the top, and then press it back into place.
 - c** Reinstall the middle screw on each side.
- 24** Reinstall and tighten the three screws that secure the top of the box to each side of the box.
- 25** Mount the 2216 in the rack. It is recommended that you use a screw starter here.
 - a** If you have a shelf, install it in the rack first. Otherwise, install the installation aid.

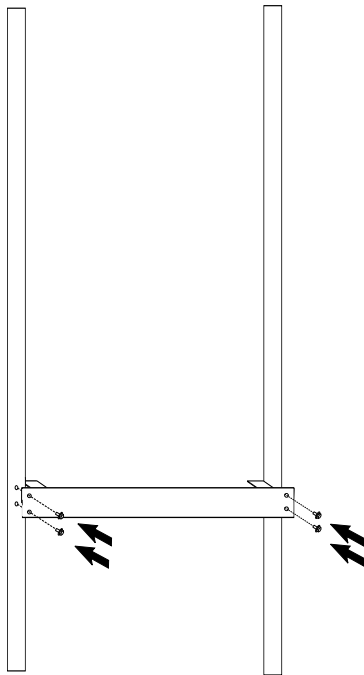

- b** Slide the 2216 into the rack.
- c** While one person holds the box in place, the other should install the bottom screw into each mounting bracket. Then install the remaining six screws.

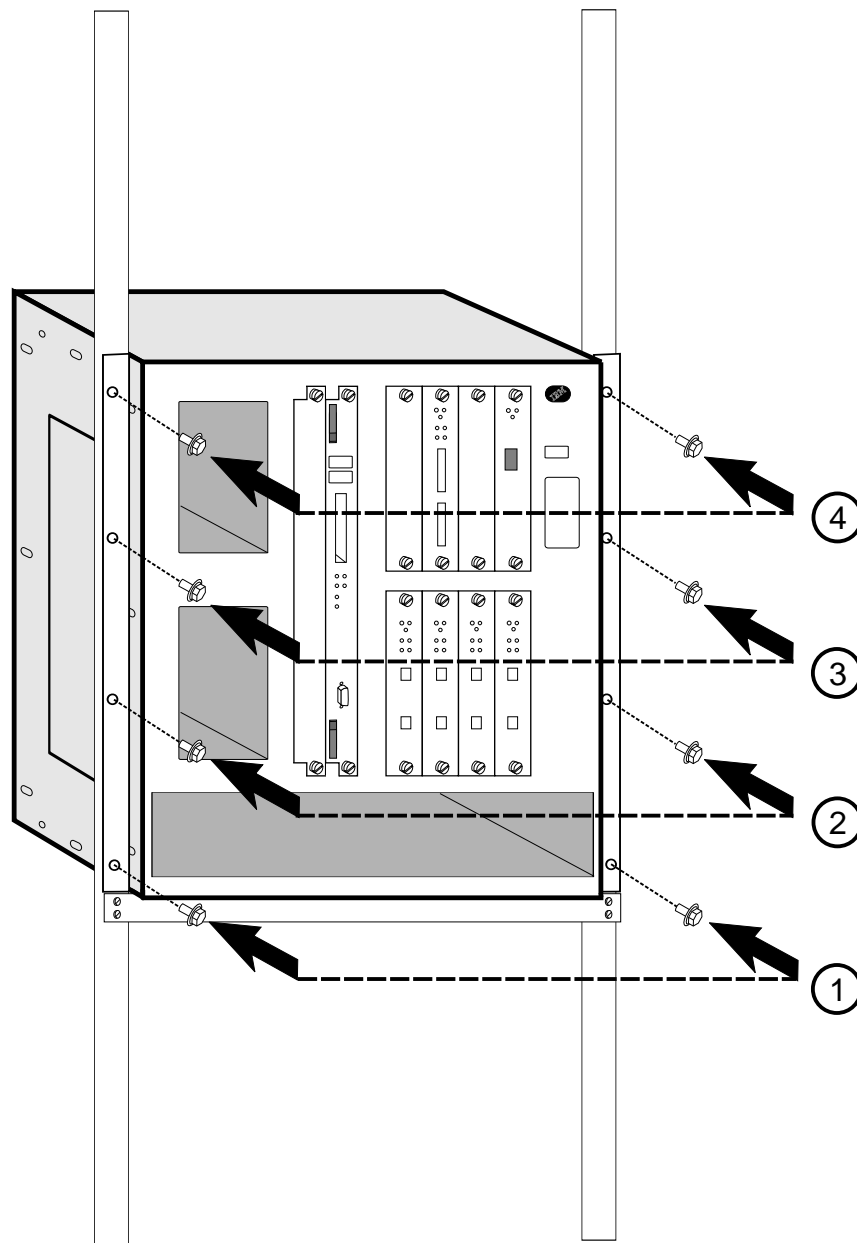

d Remove the shelf, if necessary.

- 26** Install the fan tray. Slide the fan tray in until the tabs on the back of the fan tray are in the slots. This aligns the connectors with the plugs. When the fan tray is flush with the box, tighten the two screws.

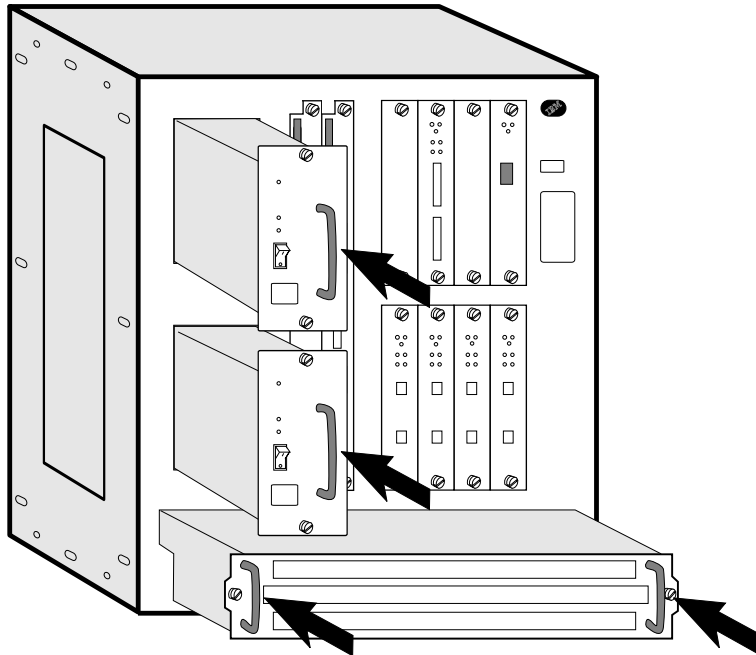

- 27** Install the slot cover into slot A.
- 28** Install the system card in slot B. Make sure the card is aligned with the plastic grooves and then slide it in until it is flush with the box. (See “Exchanging the System Card” on page 2-5 for details). Tighten the screws.
- 29** Moving from left to right, install the remaining adapters. Slide each adapter along the plastic grooves until it clicks into place. (See “Exchanging an Adapter” on page 2-14 for details.)
- 30** Finally, install the power supplies. The power supplies will slide into place by following metal rails in the box.
- 31** Connect the cables and power cord to the power receptacle.
- 32** Switch on the power.
- 33** Verify the LEDs. See “LED Indicators” on page 1-2
- 34** Notify the network administrator that you are finished repairing the 2216.

Chapter 3. Accessing the 2216

This chapter explains how to access and manage the IBM 2216's operational and configuration software.

The network administrator or the IBM Support Center can access the IBM 2216 locally or remotely for configuration or diagnostics. The following sections describe accessing the IBM 2216, configuration tools, and monitoring tools.

Access Methods

The IBM 2216 must be configured as part of the installation process. It needs either an IP address or configuration for LAN emulation. Therefore, you have to access it in one of the following ways:

- Through the PCMCIA modem or through a modem attached to the EIA 232 service port. These are the forms of remote connection, which rely on the telephone lines.
- Through a null modem cable attached to the EIA 232 service port. This is known as local connection.

You can set up both a local and a remote connection to the IBM 2216. However, only one port can be active at any given time. If a workstation is connected locally to the serial port and a call comes in over the PCMCIA modem, priority is given to the call. After the call, the workstation being used to configure will have to log back into the IBM 2216.

With local or remote connection, you can use a teletypewriter (TTY) connection. TTY requires communications software. The preferred method is to use Serial Line Internet Protocol (SLIP) over the local or remote connection. If you use SLIP, you must have Transmission Control Protocol/Internet Protocol (TCP/IP) running on your workstation.

Alternatively, you can use the Xmodem protocol and ProComm or other communication software for file transfers.

Figures 3-1 and 3-2 illustrate a remote connection using the PCMCIA modem and a local connection using a null modem.

Note: Post-installation configuration changes can be done using the Configuration Program.

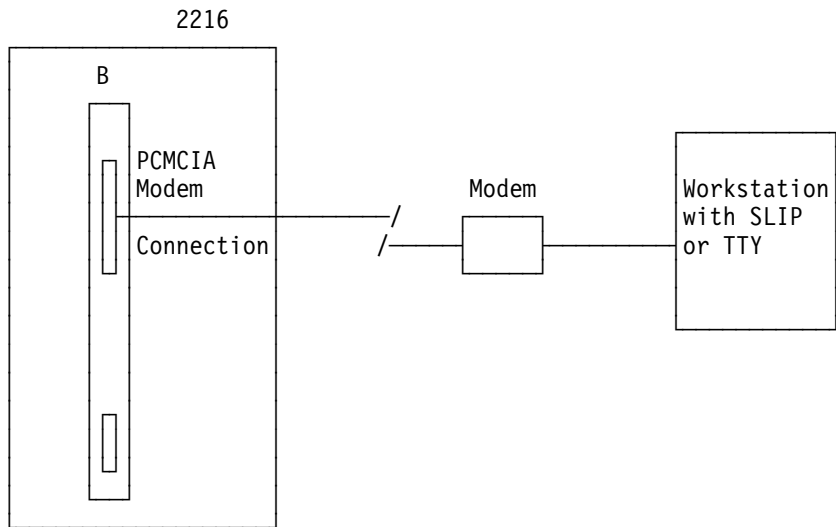

Figure 3-1. Remote Serial Connection to the PCMCIA Modem

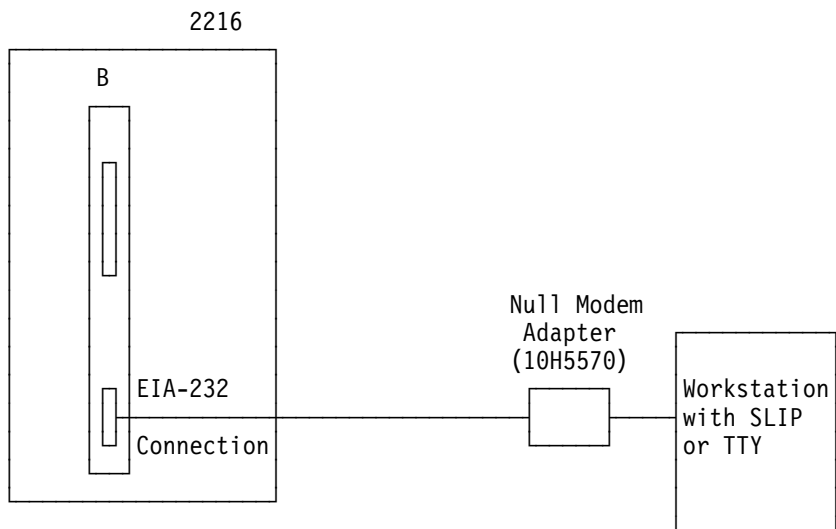

Figure 3-2. Local Serial Connection to the EIA 232 Port

SLIP Addresses

The default SLIP IP addresses are:

For the workstation:

10.1.1.3

For the IBM 2216:

10.1.1.2

For instructions about installing SLIP, refer to the documentation for your version of TCP/IP.

Serial Port and PCMCIA Modem Default Settings

These are the default settings for the serial port:

Speed	19.2 Kbps
Parity	None
Data Bits	8
Stop Bits	1

The PCMCIA modem is a standard item that is shipped with the IBM 2216. The modem is a 33.3 Kbps V.32 bis modem. It is set up with a default speed of auto-detect. The parity, data bits, and stop bits are the same as those of the serial port: None, 8, and 1.

Attaching an ASCII Terminal

Attach an ASCII terminal or emulator (with the appropriate emulation software) to provide local or remote access to the 2216 as shown in Figure 3-1 on page 3-2 and Figure 3-2 on page 3-2.

The DEC VT100 ASCII terminal is supported, as well as devices such as personal computer systems that are configured to emulate it. Configure a VT100 with:

- No parity
- 8-bit word length
- 1 stop bit
- 300 bps–38.4 Kbps bit rate

Note: The speed must match the speed of the connected terminal. It is 19.2 Kbps if the serial service port is used, any speed if the PCMCIA modem is used and is set to autobaud.

ASCII Terminal Setup Attributes

This is a list of all the options required to set up a terminal for use with the IBM 2216 that is connected to the service port. Not every terminal (particularly 3151 and 3161) will have all these options. You should use the information to set the options that you can set on your terminal.

Terminal Settings and Function Keys

Terminal Settings

Baud Rate:	19200 bits per second
Parity:	None
Stop bits:	1
Duplex:	Full Duplex
Flow Control:	XON/XOFF and RTS/CTS (see note 1)
Screen Control:	ANSI Full screen
Screen Width:	80 Characters
Screen Height:	24 Lines
Line Wrap:	ON
Screen Scroll:	ON
Carriage Return Translation:	CR (0Dx)
Backspace Translation:	Destructive

Notes:

1. Terminals and Terminal emulator programs which do not have flow control options should be set to "Permanent Request to Send".
2. Terminal emulators that require a terminal type selection should be set to VT-220.

Function Keys

Function 1 (F1):	<Esc> 0 P	Hex: 1B 4F 50
Function 2 (F2):	<Esc> 0 Q	Hex: 1B 4F 51
Function 3 (F3):	<Esc> 0 R	Hex: 1B 4F 52
Function 4 (F4):	<Esc> 0 S	Hex: 1B 4F 53
Function 6 (F6):	<Esc> [0 0 6 q	Hex: 1B 5B 30 30 36 71
Function 9 (F9):	<Esc> [0 0 9 q	Hex: 1B 5B 30 30 39 71

Note:

- In the definitions of function keys 1 through 4, the character following the <ESC> is the *capital* letter O.
- In the definition of keys 6 and 9 the characters following the <ESC> and the [are number 0 (zero).
- In all six definitions, the characters are case sensitive.

Managing the Operational and Configuration Software

The IBM 2216 comes from the factory with its operational software loaded. However, if the operational software needs an upgrade or replacement, you have to reload it. Binary configuration files can be created using the Configuration Program. These files can be uploaded to the IBM 2216 to reconfigure it.

IBM 2216 Software and Configuration Change Management

The IBM 2216 is capable of storing two copies of its operational software and four copies of configuration information for each copy of the operational software. Without interrupting the operation of the IBM 2216, you can store software or configuration files in it. Changes to the configuration are activated in one of the following ways: immediately, after a timed interval, or at the next restart.

Should the IBM 2216 fail when a new version of the operational software is activated, one of the backup versions can be restored.

You use the command line interface for change management operations and TFTP or Xmodem to transfer files.

Chapter 4. Using 2216 Firmware

The IBM 2216 firmware tests the hardware each time the IBM 2216 is powered on. If the IBM 2216 has not loaded its operational code, the firmware should be running. The firmware menu will come up and pause when the IBM 2216 is set up to boot up in "Supervisory/Attended Mode." Supervisory Mode requires direct intervention from console input to complete the boot-up process (a supervisory password is required).

Important:

1. You can also access the firmware by stopping the boot process. To do this, you must have a TTY console directly attached to the serial port and a null modem.
2. To access the firmware:
 - a. When the IBM 2216 starts its boot process, press **F1** at the terminal keyboard.
 - b. If the firmware panels do not appear:
 - 1) Make sure your workstation is connected to the serial port on the IBM 2216
 - 2) Power off, and power on, the IBM 2216.

Note: Make sure the screen size for your terminal emulation software is set to 80 columns by 24 rows.

Connection in Supervisory mode is a TTY (using limited VT100, VT220, IBM 3151 or 3161 emulation) connection. You can transfer files using the Xmodem protocol for TTY.

Supervisory/Attended Mode

When the IBM 2216 is configured to come up in Attended mode, you are given access to the Firmware command set. (A supervisory password is required for access to the firmware.) From this level of commands, you can select the Image Bank from which to load. You can also choose the config file from within that Image Bank. At this point, you can load new config files or image files.

In Attended mode, you can start booting the IBM 2216 by pressing **F9** to start the operating system.

Unattended Mode

This is the normal mode for the IBM 2216. (A password is not required to access the firmware in unattended mode.) To do this, you must have a TTY console directly attached to the serial port and a null modem.

Starting Firmware

You are ready to begin using the information in this chapter after you have prepared your service terminal (as described in “Attaching an ASCII Terminal” on page 3-3) and have established connection with the IBM 2216.

The firmware menu will come up when you power on the 2216 and stop the boot process by pressing **F1**. From the menu (as shown in Figure 4-1), you can select from four services. The following sections explain these services and provide instructions for using the associated panels:

- “Managing the Configuration” on page 4-3.
- “Selecting the Boot Sequence” on page 4-5.
- “Selecting a Device To Test” on page 4-7.
- “Using the Utilities” on page 4-8.

```
Nways System Firmware
Version 1.0
(C) Copyright IBM Corporation, 1996 All Rights Reserved.
                        System Management Services

Select one:
 1. Manage Configuration
 2. Boot Sequence Selection
 3. Select Device to Test
 4. Utilities

Enter   -   Esc=Quit   -   F1=Help   -   F3=Reboot   -   F9=Start OS -
-----
```

Figure 4-1. Main Menu Panel

The Function Keys

As seen in Figure 4-1, various function keys appear in the lower part of the panel. (You can also use the **Esc** keys in combination with number keys to perform the functions.) These keys are common among the firmware panels. On other panels, the function keys are stacked at the right of the panel. Use the **F1** Help key (or **Esc - 1**) to get descriptions for the function keys associated with the firmware.

Obtaining Help

Online helps are available for panels whenever the F1 key is displayed in the lower portion of the panel. Pressing F1 presents a pop-up help window with information relating to the currently active panel.

Managing the Configuration

Managing the configuration involves defining and modifying some configuration values. You can change operational parameters for the serial ports, as well as the values of the boot flags.

- 1** Select **1. Manage Configuration** from the main menu as shown in Figure 4-1 on page 4-2.
- 2** The System Configuration Information panel is displayed as shown in Figure 4-2 on page 4-4. Only the fields under Serial Ports and Boot Flags can be modified.
- 3** To modify a field, move the cursor to the field, press **Enter**, and select or type in the new value.
- 4** For serial ports, you can modify the port or PCMCIA modem's speed, parity, and the number of data and stop bits. Boot flags are defined as follows:

Fast Boot

disabled The default. When disabled all diagnostics are run on every boot attempt.

enabled The router skips Power On Self Test hardware diagnostics, resulting in a faster boot time but less hardware error checking.

Stop On Error

disabled The default. When disabled, the router proceeds booting the operating system without regard to diagnostic results.

enabled The router stops the boot sequence in the firmware if any of the POST diagnostic tests fail, instead of proceeding to boot the router operating system. You may then view the error log to determine the cause of failure.

Notes:

- a. This option is ignored when Fast Boot is enabled.
- b. This option does not affect the PCI diagnostics that are run at boot-time by the router operational code.
- c. POST diagnostics check out the system card, memory, and hard disk. They can report errors that would not actually prohibit the router from operating successfully.

Use the down arrow (↓) key to scroll to the next panel.

```

Nways System Firmware
Version 2.10
(C)Copyright IBM Corporation, 1997. All rights reserved.
+-----System Configuration Information-----+
Se | Processor Type          133 MHz 604
1  | Memory                  64 Megabytes                >
2  | Serial Ports
3  |   COM1 (x' 3f8')        Serial Port                >
4  |   COM2 (x' 2f8')        PCMCIA Modem                >
   |
   | Boot Flags
   |   Fast Boot              Disabled                >
   |   Stop On Error          Disabled
   |
   | L2 Cache                 512KB Installed
   |
   | PCI Slots
   | Name of Adapter        Slot #      Device ID      Revision ID
   | 060000                  B           0037           02
   | 060100                  B           000a           03
   | Unknown( 0001 010000 )  B           0100           01
   | 060400                  B           0022           01
   | 060400                  B           0022           01
   | Unknown( 104c 060700 ) B           ac15           01
   | ff0000                  B           0046           00
   |
   | Enter - Esc=Quit - F1=Help -
   |-----+

```

Figure 4-2. System Configuration Information

```
Nways System Firmware
Version 1.0
(C) Copyright IBM Corporation, 1996 All Rights Reserved.
System Management Services

Select one:
1. Manage +-----Current Boot Sequence-----+
2. Boot Se
3. Select   Your current boot sequence is:
4. Utiliti
           1. IDE Disk Drive      ID 0, IBM-DS0A-21080
           2. PCMCIA Modem       Not installed
           3. EIA 232 Port      ID 0, IBM SLIP, EIA 232 Port
           4. None
           5. None

           Enter -
           -----

Enter - Esc=Quit - F1=Help - F3=Reboot - F9=Start OS -
-----
```

Figure 4-4. Current Boot Sequence

Using the Utilities

To use the utilities:

- 1** Select **4. Utilities** from the main menu.
- 2** A menu listing the available utilities is displayed (Figure 4-6).

```
Nways System Firmware
Version 1.0
(C) Copyright IBM Corporation, 1996 All Rights Reserved.
                        System Management Utilities

Select one:
 1. Set Power-On Password
 2. Set Supervisory Password
 3. Enable Unattended Start Mode
 4. Disable Unattended Start Mode
 5. Remove Power-On Password
 6. Remove Supervisory Password
 7. Update System Firmware
 8. Display Error Log
 9. View or Set Vital Product Data
10. Manipulate Dead Man Timer
11. Remote Initial Program Load Setup
12. Change Management
13. Prepare Hard Disk
Enter   -   Esc=Quit   -   F1=Help   -
-----
```

Figure 4-6. Utilities Selection Panel

- 3** Make your selection. You will be prompted for additional information, and messages are displayed to indicate that the task was performed.

Setting the Power-On Password

If a password is set/installed and the IBM 2216 is not in unattended mode, you must set a power-on password before operational code can be loaded in the IBM 2216. The IBM 2216 is initially shipped with a password of **2216**. This utility allows you to set and change the password.

This function can be performed only if done immediately after switching the power on.

1 Select **1. Set Power-On Password** from the utilities panel. The Set Power-On Password panel is displayed (Figure 4-7).

2 Type your new password and press **Enter**. You are prompted to enter your new password again.

Note: The power-on password can consist of from 1 to 8 characters with no restrictions on which characters can be used.

```
Nways System Firmware
Version 1.0
(C) Copyright IBM Corporation, 1996 All Rights Reserved.
                        System Management Utilities

Select one:
1. Set Power-On Password-----Set Power-On Password-----+
2. Set Supervisor
3. Enable Unatten      Type your new password, and then
4. Disable Unatten    press Enter.
5. Remove Power-On
6. Remove Supervi
7. Update System      Enter - F1=Help - Esc=Quit
8. Display Error
9. View or Set Vi+-----+
10. Manipulate Dead Man Timer
11. Remote Initial Program Load Setup
12. Change Management
13. Prepare Hard Disk
Enter - Esc=Quit - F1=Help -
-----
```

Figure 4-7. Set Power-On Password Panel

3 Type the password again and press **Enter**.

4 The Password Saved panel is displayed with the message that your power-on password has been saved.

Setting the Supervisory Password

If a supervisory password is set, the password must be entered prior being able to access to the "System Management Services." You must set a supervisory password before operational code can be loaded in the IBM 2216. The IBM 2216 is initially shipped with a password of **2216**. This utility allows you to set and change the password.

This function can be performed only if done immediately after switching the power on.

- 1** Select **2. Set Supervisory Password** from the utilities panel. The Set Supervisory Password panel is displayed (Figure 4-8).
- 2** Type your new password and press **Enter**. You are prompted to enter your new password again.

Note: The supervisory password can consist of from 1 to 8 characters with no restrictions on which characters can be used.

```
Nways System Firmware
Version 1.0
(C) Copyright IBM Corporation, 1996 All Rights Reserved.
                        System Management Utilities

Select one:
 1. Set Power-On P+-----Set Supervisory Password-----+
 2. Set Supervisor |
 3. Enable Unatten | Type your new password, and then
 4. Disable Unatte | press Enter.
 5. Remove Power-0 |
 6. Remove Supervi |
 7. Update System | Enter - F1=Help - Esc=Quit
 8. Display Error | -----
 9. View or Set Vi+-----+
10. Manipulate Dead Man Timer
11. Remote Initial Program Load Setup
12. Change Management
13. Prepare Hard Disk
Enter - Esc=Quit - F1=Help -
-----
```

Figure 4-8. Set Supervisory Password Panel

- 3** Type the password again and press **Enter**.
- 4** The Password Saved panel is displayed with the message that your supervisory password has been saved.

Enabling Unattended Start Mode

The default is that Unattended start mode is enabled. This causes the IBM 2216 to load operational code automatically.

This function can be performed only if done immediately after switching the power on.

- 1** Select **3. Enable Unattended Start Mode** from the utilities panel. The Unattended Start Mode Changed panel is displayed (Figure 4-9).
- 2** Press **Enter**.

```
Nways System Firmware
Version 1.0
(C) Copyright IBM Corporation, 1996 All Rights Reserved.
                        System Management Utilities

Select one:
 1. Set Power-On Password
 2. Set Supervisor+-----Unattended Start Mode Changed-----+
 3. Enable Unatten|
 4. Disable Unatte|   Unattended start mode has been
 5. Remove Power-0|   enabled.
 6. Remove Supervi|
 7. Update System  |   Enter -
 8. Display Error  |   -----
 9. View or Set Vi+-----+
10. Manipulate Dead Man Timer
11. Remote Initial Program Load Setup
12. Change Management
13. Prepare Hard Disk

Enter - Esc=Quit - F1=Help -
-----
```

Figure 4-9. Unattended Start Mode Changed (Enabled) Panel

Note: After you have enabled Unattended start mode, you can enter the firmware by pressing and holding **F1** at the terminal keyboard when the boot process begins.

Disabling Unattended Start Mode

The default for the IBM 2216 firmware is that the Unattended start mode is enabled. You disable Unattended Start Mode using this utility.

Note: This function can be performed only if done immediately after switching the power on.

- 1** Select **4. Disable Unattended Start Mode** from the utilities panel. The Unattended Start Mode Changed panel is displayed (Figure 4-10).
- 2** This panel informs you that the Unattended start mode has been disabled and prompts you to press **Enter**.

```
Nways System Firmware
Version 1.0
(C) Copyright IBM Corporation, 1996 All Rights Reserved.
                        System Management Utilities

Select one:
 1. Set Power-On Password
 2. Set Supervisory Password
 3. Enable Unatten+-----Unattended Start Mode Changed-----+
 4. Disable Unatte|
 5. Remove Power-0|      Unattended start mode has been
 6. Remove Supervi|      disabled.
 7. Update System  |
 8. Display Error  |      Enter  -
 9. View or Set Vi|      -----
10. Manipulate Dea+-----+
11. Remote Initial Program Load Setup
12. Change Management
13. Prepare Hard Disk

Enter  -   Esc=Quit  -   F1=Help  -
-----  -----  -----
```

Figure 4-10. Unattended Start Mode Changed (Disabled) Panel

Removing the Supervisory Password

The use of a supervisory password allows you a degree of security by preventing unauthorized access to the IBM 2216. However, removing the enforcement of the password could be a convenience while servicing the IBM 2216.

Note: This function can be performed only if done immediately after switching the power on.

- 1** Select **6. Remove Supervisory Password** from the utilities panel.
- 2** The Remove Supervisory Password panel is displayed (Figure 4-11).

```
Nways System Firmware
Version 1.0
(C) Copyright IBM Corporation, 1996 All Rights Reserved.
                        System Management Utilities

Select one:
 1. Set Power-On Password
 2. Set Supervisory Password
 3. Enable Unatten+-----Remove Supervisory Password-----+
 4. Disable Unatte|
 5. Remove Power-0| Do you want to remove the
 6. Remove Supervi| Supervisory password?
 7. Update System  |
 8. Display Error  | Yes -   No -
 9. View or Set Vi | -----
10. Manipulate Dea+-----+
11. Remote Initial Program Load Setup
12. Change Management
13. Prepare Hard Disk

Enter - Esc=Quit - F1=Help -
-----
```

Figure 4-11. Remove Supervisory Password Panel

- 3** Select **Yes** if you want to remove the supervisory password. Press **Enter**.
- 4** The Password Removed panel is displayed. This panel informs you that the supervisory password has been removed.

Updating System Firmware

Use this utility to update the IBM 2216 firmware. Only full images of the firmware are shipped; therefore, when you select this option you completely replace the previous level of firmware.

- 1 Select **7. Update System Firmware** from the utilities panel.
- 2 The System Firmware Update panel is displayed (Figure 4-12).

```
Nways System Firmware
Version 1.0
(C) Copyright IBM Corporation, 1996 All Rights Reserved.
                        System Management Utilities

Select one:
  1. Set Power-On Password
  2. Set Supervisory Password
  3. Enable Unattended Start Mode
  4. Disable Unattended Start Mode
  5. Remove Power-On+-----F/W Update Options-----+
  6. Remove Supervi
  7. Update System   | 1. TFTP a Remote Image File
  8. Display Error   | 2. XMODEM a Remote Image File
  9. View or Set Vi  | 3. Use a Local Image File
10. Manipulate Dea
11. Remote Initial   | Enter - Esc=Quit - F-1=Help
12. Change Managem  | -----
13. Prepare Hard D+-----+

Enter - Esc=Quit - F1=Help -
-----
```

Figure 4-12. System Firmware Update Panel

Attention: Do not power off the IBM 2216 during the process of updating the firmware. If the update fails, the IBM 2216 will boot a backup firmware image. If this happens, repeat the update procedure to reload the onboard firmware image.

- 3 Select the option that you want to use from those listed. For TFTP, you will be prompted for a local (the “to”) and a remote (the “from”) file names that you want use (and the name of the server that can be reached by the IBM 2216). In addition, you will be prompted to create a recovery image and a file name from which to update the firmware.

TFTP will not function with a slip interface.

The firmware update process begins. It informs you that the system firmware has been updated.

Sample Steps for Installing New System Firmware Using Xmodem

Before starting this procedure, connect a terminal emulator to the 2216 (see Chapter 3, "Accessing the 2216" on page 3-1).

This is a two-part process. The firmware image is transferred to the 2216 and is then burned into the 2216 system flash.

1 From the F/W Update Options menu, select **2. XMODEM a Remote Image File**.

2 Type in the filename (for example, eptf5.ld) that you want to use for the temporary file that will be copied onto the C: drive of the 2216.

A message states to start the Xmodem transfer when the window is closed. This process is dependent on the terminal emulation package that you are using.

The transfer process is time-sensitive and may time out before the process starts. Restart from the F/W Update Options menu if necessary.

- If characters like '\$' appear by the message box, it means that the connection is not established.
- If 10-12 appears, Xmodem will likely time out and need to be restarted.

3 After Xmodem completes, a message similar to the following is displayed:

```
This selection will update your
system firmware. Do you want to
continue?
```

The system asks if you want to build a recovery block. It is optional, but recommended.

Note: Be patient, as the system writes from RAM to the hard drive. It may take up to 5 minutes.

4 After building a recovery block, additional messages will be displayed.

5 The system displays the file choices for firmware update. Choose the file that was just uploaded. The choices should look similar to those below:

```
( ) C:PRECOVER.IMG    03/20/97
(>) C:FIRM.LD        04/07/97
```

6 Answer **yes**, and the system updates the firmware.

Note: Do not switch the system off. The process erases the old firmware and copies the new firmware into flash memory. If the machine is powered off before the process is complete, you will need to reload the firmware from the recovery image.

7 A completed message appears when the firmware is updated.

Displaying the Error Log

The error log is resident in NVRAM (not on the hard drive). See Appendix A, "Hardware Error Codes" on page A-1 to interpret the data that appears in the Error Code field.

- 1** Select **8. Display Error Log** from the utilities panel.
- 2** The Error Log panel is displayed (Figure 4-13). See Appendix A, "Hardware Error Codes" on page A-1 for an explanation of the data that appears in the Error Codes field.

```
Nways System Firmware
Version 1.0
(C) Copyright IBM Corporation, 1996 All Rights Reserved.
                        System Management Utilities

Select one:
 1. Set Power-On Password
 2. Set Supervisory Password
 3. Enable Unattended Start Mode
 4. Disable Unattended Start Mode
 5. Remove Power-On Password
-----Event Log-----+
| 1. Src      1 08/src/arp/sysex/c200/io_int.c:324      00000005,012B
| 2. Bootup  0*****                                00-01, 21 01/03/96 16:23:27
| 3. Src      1 08/src/arp/sysex/c200/io_int.c:324      00000005,012B
|
|   Enter    -   Esc=Quit  -   F1=Help   -   F2=Clear Error Log -
| -----
|-----+
Enter - Esc=Quit - F1=Help -
-----
```

Figure 4-13. Error Log Panel

Viewing or Setting Vital Product Data

This utility allows you to view vital product data (VPD) for the IBM 2216. The system serial number is entered at the factory, but can be changed on the panel that appears after you select to view or set the VPD.

- 1** Select **9. View or Set Vital Product Data** from the utilities panel.
- 2** The View or Set Vital Product Data panel is displayed (Figure 4-14). From this panel you can select the type of vital product data you want to view or set. The serial number field is the only field (under the "Hardware Vital Product Data" menu) that is modifiable; Firmware Part Number is only viewable.

```
Nways System Firmware
Version 1.0
(C) Copyright IBM Corporation, 1996 All Rights Reserved.
                        System Management Utilities

Select one:
 1. Set Power-On Password
 2. Set Supervisory Password
 3. Enable Unattended Start Mode
 4. Disable Unattended Start Mode
 5. Remove Power-On Password
 6. Remove Supervisory Password
 7. Update System Firmware +-----View or Set Vital Product Data-----+
 8. Display Error Log
 9. View or Set Vital Product
10. Manipulate Dead Man Time | Firmware Part Number
11. Remote Initial Program L | Hardware Vital Product Data
12. Change Management
13. Prepare Hard Disk
                               Enter - Esc=Quit - F1=Help -
Enter - Esc=Quit - -----+-----
```

Figure 4-14. View or Set Vital Product Data Panel

- 3** For each selection, a View or Set Part Number panel is displayed that contains the part number you selected. Version number and dates are provided for the firmware and System Management Services.
- 4** If you want to view or change vital product data, select **Hardware Vital Product Data**.

5 The hardware VPD is stored in keyword format. The following is a list of the keywords and their meanings. Depending on the configuration of your system, not all of the keywords listed are necessarily present or have meaningful values.

- AT - Main logic card type
- DS - Text description of card
- FN - FRU number
- PN - Manufacturing part number
- ML - Maintenance level
- MF - Manufacturing location
- SN - Serial number
- BF - Boot flash level and ID
- NA - Burned-in MAC Address in ASCII Format
- ZB - Burned-in MAC Address in Hex Canonical Format
- TM - Machine type and model
- F# - Feature Number
- BS - Box serial number
- RC - Recycle count
- Z0 - Vendor ID

Setting Up Remote Initial Program Load

This utility allows you to load this minimum information to install this device in your network so that you can send it a configuration file or otherwise communicate with it. This utility allows you to Ping the IBM 2216, after loading its minimum network parameters, to see if you can communicate with it.

- 1** Select **11. Remote Initial Program Load Setup** from the utilities panel.
- 2** The “Network Parameters” panel is displayed (Figure 4-15). From this panel, you can select to enter the IP address of the IBM 2216 and the host, input PCMCIA adapter parameters, or Ping from the IBM 2216 to the host.

```
Nways System Firmware
Version 1.0
(C) Copyright IBM Corporation, 1996 All Rights Reserved.
System Management Utilities

Select one:
 1. Set Power-On Password +----- Network Parameters -----+
 2. Set Supervisory Password |
 3. Enable Unattended Start |           1. IP Parameters
 4. Disable Unattended Start |           2. Adapter Parameters
 5. Remove Power-On Password |           3. Ping
 6. Remove Supervisory Passw |
 7. Update System Firmware |
 8. Display Error Log |           Enter - Esc=Quit - F1=Help -
 9. View or Set Vital Produc |-----+
10. Manipulate Dead Man Time+-----+
11. Remote Initial Program Load Setup
12. Change Management
13. Prepare Hard Disk

Enter - Esc=Quit - F1=Help -
-----
```

Figure 4-15. Setup Remote Initial Program Load Panel

- If you select **IP Parameters**, a panel will be displayed on which you can enter:
 - Client IP Address (the IP address of the IBM 2216)
 - Server IP Address
 - Gateway IP Address
 - Subnet Mask

An IBM 2216 comes from the factory with the following default IP addresses:

Client	111.11.11.11
Server	111.11.11.10
Gateway	111.11.11.10
Subnet mask	255.255.255.0

- 3** The **Ping** option allows you to test connectivity.

Manipulating the Dead Man Timer

This utility allows you to selectively enable or disable the dead man timer. The dead man timer has a granularity of 0.25 seconds and expires in 10 seconds. This tool would be useful in some troubleshooting procedures.

- 1** Select **10. Manipulate Dead Man Timer** from the utilities panel.
- 2** A Dead Man Timer Options panel is displayed. From this panel you can enable or disable the timer.

```
Nways System Firmware
Version 1.0
(C) Copyright IBM Corporation, 1996 All Rights Reserved.
                          System Management Utilities

Select one:
  1. Set Supervisory Password
  2. Enable Unattended Start Mode
  3. Disable Unattended Start Mode
  4. Remove Supervisory Password
  5. Update System Firmware
  6. Display Error Log
  7. View or Set Vital Product Data
  8. Copy Remote Files
  9. Remote Initial Program Load
 10. Manipulate Dead Man Time+-----Dead Man Timer Options-----+
 11. Remote Initial Program
 12. Change Management      |           1. Enable Dead Man Timer           |
 13. Prepare Hard Disk      |           2. Disable Dead Man Timer          |
                             |-----+-----|
Enter   -   Esc=Quit   -   |           Enter - Esc=Quit - F1=Help -           |
-----+-----+-----+-----+-----+-----+-----+-----+-----+

```

Figure 4-16. Manipulate Dead Man Timer Panel

Change Management

Change Management enables you to manipulate the 2216 level of software code that will run on the 2216 (Appendix D, “Managing Operational Code and Configuration Files” on page D-1 has additional information about change management.

Xmodem Software Selection

The Xmodem protocol is supported only from the “System Management Services” menu. To access the “System Management Services” menu, you have to either interrupt the boot-up sequence or bring up the IBM 2216 in Attended mode. The Change Management command is available from the “System Management Utilities” option of the Main Menu. From that point, the IBM 2216 will direct you as to what to transfer in and where to put the image.

Notes:

1. When the IBM 2216 is in firmware mode, there is no active configuration or image. Therefore, you should use caution when specifying where to write new images or configurations.
2. When using Xmodem to transfer a multiple load module image (used in Release 2 in the form of several files ending in .ld), **you must** transfer each of the modules (.ld files) one by one to get the entire load module image.

When an entire load image has transferred, the status of the bank will change from CORRUPT to AVAIL. Transfer file LML.ld first. Unless you see an information message ERROR WRITING FILE appear, assume each individual transfer has been successful.

When you are finished with file transfer, select **List software** on the Change Management menu. The status will have changed to AVAIL for that bank that has the new load image.

The following sample menus are associated with Xmodem download. These menus show the text that is displayed when you choose Change Management.

Examples:

```
Nways System Firmware
Version 1.0
(C) Copyright IBM Corporation, 1996 All Rights Reserved.

                                Change Management Software Control

Select one:
1. Add Description Data
2. Describe Software
3. Control Rebooting of Router
4. Control Dumping of Router
5. Copy Software
6. Erase Software
7. List Software
8. Lock Config File
9. Set Boot Information
10. TFTP Software
11. Unlock Config File
12. XMODEM Software

Enter - Esc=Quit - F1=Help -
-----
```

1 Select 5. Copy Software.

```
Nways System Firmware
Version 1.0
(C) Copyright IBM Corporation, 1996 All Rights Reserved.

                                Change Management Software Control

1. Add Description Data
2. Describe Software
3. Control Rebooting of Router
4. Control Dumping of Router +-----Select Type-----+
5. Copy Software |
6. Erase Software |           1. Config
7. List Software |           2. Load Image
8. Lock Config File |
9. Set Boot Informa |           Enter - Esc=Quit - F1=Help -
10. TFTP Software |           -----
11. Unlock Config Fi+-----+
12. XMODEM Software

Enter - Esc=Quit - F1=Help -
-----
```

2 Select either **Config** (for configuration file) or **Load Image** (for the operational software file).

The following figure is an example of the Load Image selection.

```

Nways System Firmware
Version 1.0
(C) Copyright IBM Corporation, 1996 All Rights Reserved.
System Management Utilities

                2216 Software Control
+-----+-----+-----+
| BANK A | | Description | | Date |
+-----+-----+-----+
| IMAGE - AVAIL | | | | -14256 Jan 1970 - |
| CONFIG 1 - PENDING | | | | -14256 Jan 1970 - |
| CONFIG 2 - NONE | | | | -14256 Jan 1970 - |
| CONFIG 3 - NONE | | | | -14256 Jan 1970 - |
| CONFIG 4 - NONE | | | | -14256 Jan 1970 - |
+-----+-----+-----+
| BANK B | | Description | | Date |
+-----+-----+-----+
| IMAGE - PENDING | | | | -14256 Jan 1970 - |
| CONFIG 1 - NONE | | | | 02 Jan 1994 20:39 |
| CONFIG 2 - NONE | | | | 02 Jan 1994 20:41 |
| CONFIG 3 - NONE | | | | 1994 20:43 |
| CONFIG 4 - NONE | | | | 1994 20:45 |
+-----+-----+-----+
* - Last Used Config      L - Config F      Enter
12. XMODEM Software      1. Bank A      -----
                        2. Bank B      Esc=Quit
                        F1=Help      F1=Help
Enter - Esc=Quit - F1=Help -
+-----+-----+-----+

```

The following figure is an example of the Config selection.

```

Nways System Firmware
Version 1.0
(C) Copyright IBM Corporation, 1996 All Rights Reserved.
System Management Utilities

                2216 Software Control
+-----+-----+
| BANK A | | BANK B |
+-----+-----+
| IMAGE - PENDING | | IMAGE - AVAIL |
| CONFIG 1 - PENDING | | CONFIG 1 - NONE |
| CONFIG 2 - NONE | | CONFIG 2 - NONE |
| CONFIG 3 - NONE | | CONFIG 3 - NONE |
| CONFIG 4 - NONE | | CONFIG 4 - NONE |
+-----+-----+
XMODEM Software      +Select Destination Config+
                        Config 1      Enter -
                        Config 2      -----
                        Config 3      -----
                        Config 4      -----
                        F1=Help      F1=Help
Enter - Esc=Quit - F1=Help -
+-----+-----+-----+

```

Chapter 5. Using Operational Diagnostics

Operational diagnostics for the IBM 2216 can be invoked through the command line interface. You can invoke the IBM 2216 operational diagnostics using the local terminal connection or from the Support Center using a remote connection.

If the IBM 2216 is not configured (booted up and in config-only mode), operational diagnostics cannot be invoked.

This chapter describes general procedures for invoking operational diagnostics and includes sample screens.

Overview of Diagnostic Functions and Status Information

Diagnostics are available to test each adapter. In some cases, you may also be able to test individual ports of multi-port adapters. These tests execute concurrently with normal operation on other adapters and ports.

You can use the following types of diagnostic pages:

- **Device List** to show a summary list of devices.
- **Device Status and Control** to allow you to disable and test a device
- **Test Results** to present the results of the test for a device.
- **Test Options** to allow you to choose specific testing options for a device.
- **Setup for Loop Test** to prompt for the presence of diagnostic aids such as wrap plugs.
- The **Restore from Loop Test** to prompt you to remove diagnostic aids that have been installed prior to testing.

Many of the diagnostic pages have help information that provides definitions of the status fields and testing options.

These diagnostics operate in a multi-tasking environment that allows several diagnostic processes to be active at the same time. The Diagnostic Control Program controls which test processes are active and which one has access to the user interface.

When you make a selection from the Device Status and Control Page for a device, a separate testing process is started that runs independently of the other diagnostic menus. You can then go back to the Device List page or exit the diagnostic menus, returning later to view the results of the test.

When an active test process wants to report results or obtain information from you, the diagnostic status for the device will change to MESSAGE. When you select the device on the Device List page, the testing process will be given access to the console interface and the message will be displayed.

Note: It is necessary to “refresh” the Device List and Device Status and Control pages in order to see the changing status of active test processes.

Using the Command Line Interface Operational Diagnostics

The following example shows how to access the IBM 2216 diagnostics through the command line interface:

- 1** At the asterisk (*), type **diags** and press **Enter**.
- 2** The Diagnostic Menu appears (Figure 5-1). To make your selection, type in the number of your choice and press **Enter**.

```
DIAGNOSTIC MENU

Select from the following list of functions:

<1. The Device List>
  shows operational and diagnostic status for each of the installed devices.
  From this page you can also link to the Device Status and Control page
  for each adapter.

<2. The Diagnostic Test History Log>
  contains a summary of recent diagnostic testing activity.

<3. The Diagnostic Error Log>
  contains error information for recent diagnostic tests that have
  detected errors.

First time users should review the <4.Introduction> to using the diagnostics.

Select (1-4 or E=Exit Diagnostics):
```

Figure 5-1. Operational Diagnostics Main Menu

- 3** Select **<1. The Device List >** to view a list of installed devices. (Status and test options for each device are from the Device List page.) The Device Status and Control panel (similar to the one in Figure 5-2 on page 5-3) appears.

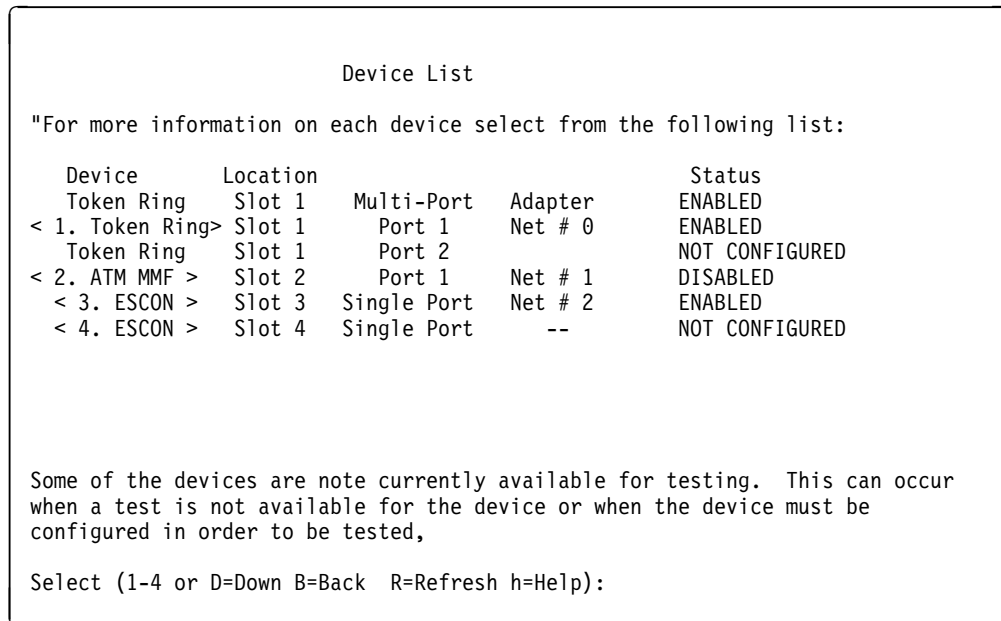

Figure 5-2. Sample of Device List Panel Showing Interfaces

The Device List is the starting point for running a test. It also provides a check to determine if all of the installed devices are being recognized by the 2216.

The Device List includes a summary status for each device. The devices that are testable or that have additional status available can be selected. Selecting a device will then display the Device Status and Control page for that device.

The Status displayed for a device may have the following values:

- ENABLED** Device is enabled for normal operation. For multi-port devices this means that at least one port is enabled.
- ENABLE PENDING** Waiting for completion of Enable request.
- Special** Device is in a special state that is explained on the Device Status and Control Page.
- DISABLED** Device is Disabled. Diagnostic testing can now be performed. For multi-port Devices this means that all ports are disabled.
- DISABLE PENDING** Waiting for completion of Disable request.
- MESSAGE** Select the device to view and respond to the message.
- TESTING** The device is being tested.
- NOT CONFIGURED** The device is not configured for normal operation.
- MIS CONFIGURED** The configuration does not match the physical device.
- HARDWARE ERROR** A Hardware Error has been detected which prevents further use of the device.

- 4** If you select the ATM interface (<2. **ATM MMF**> on the Device List panel), the Device Status and Control panel for the ATM adapter appears (Figure 5-3 on page 5-4).

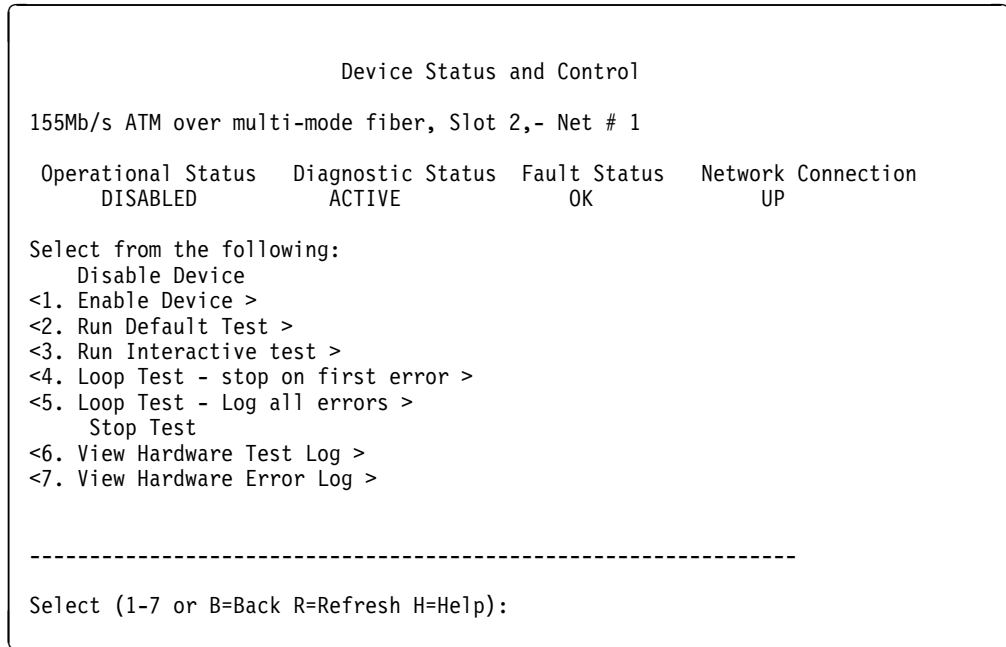

Figure 5-3. Device Status and Control Panel (Device Disabled)

The Device Status and Control Page displays status and a menu of actions for the selected device. The status fields that are displayed are dependent on the characteristics of the device.

The menu items that are active on the Device Status and Control panel are dynamically determined depending on the state of the device (that is, whether it is enabled, disabled, or testing).

In this example, the device is disabled. The Enable Device choice and all of the choices to start a test are active and can be selected. If the device were enabled, it would need to be disabled before testing.

- When the Device Status and Control panel is displayed (and the status for the device is ENABLED), you can disable the device by selecting the Disable option.
- When testing is complete, the device can be enabled using the diagnostic menus or using the router's **talk 5** commands.
- After the message Diagnostic Test for **adapter_x** has status available appears, select **Refresh** to show the status information for a device.

The status fields which are displayed for most devices have the following meanings:

- **Operational Status**

ENABLED

The device is enabled for normal operation. For multi-port devices this means that at least one port is enabled.

ENABLED PENDING	Waiting for completion of Enable request.
See Note	The device is in a special state that is explained on the Page.
DISABLED	The device is Disabled. Diagnostic testing can now be performed. For multi-port Devices this means that all ports are disabled.
DISABLE PENDING	Waiting for completion of Disable request.
DIAGNOSTICS	A configured device is being used by the diagnostics.
NOT CONFIGURED	The device is not configured for normal operation.
MIS CONFIGURED	The configuration does not match the physical device.
HARDWARE ERROR	A hardware error has been detected that prevents further use of the device.
• Diagnostic Status	
INACTIVE	Diagnostic for the device is not running.
TESTING	A testing process for the device is active and the device is being tested.
LOOP AND LOG	A testing process for the device is active and will loop and log any errors until stopped.
LOOP UNTIL ERROR	A testing process for the device is active and will loop until an error occurs or it is stopped.
MESSAGE	A testing process for the device is active and it is waiting for user input.
• Fault Status	
OK	The last test of the device completed without error.
ISOLATED	A hardware failure has been detected and isolated to the device.
NON-ISOLATED	A problem has been detected, but the failure may be external to the device. This most often occurs with network adapters that have external cables, modems, or LAN connections. Running a diagnostic of the adapter with a wrap plug attached can usually determine if the adapter has failed.
UNKNOWN	No test results are currently available for the device.

- **Network Status**

UP	The network connection is established.
DOWN	A network connection cannot be detected.
TESTING	The router is attempting to determine if a network connection exists.
UNKNOWN	The state of a network connection cannot be determined at this time.
N/A	Network Status does not apply to this device.

Explanation of menu choices

While all of the menu choices are displayed for each device, only those that are appropriate for the current state of the device will be active for a selection.

Enable Device The device will be enabled for normal operation. This performs the same function as the **enable** or **test** commands available at the router's monitoring (talk 5) prompt (+).

Disable Device The device is taken out of its normal operational state. If this menu option is available, then the device must be disabled before any diagnostic test can be started. This performs the same function as the **disable** command available at the router's monitoring (talk 5) console.

Run Default Test This starts a test which assumes that the device is set up for normal operation. For communication adapters this means that it has a cable attached and is connected to the network.

Run Interactive Test This starts a test which will present an additional menu of options such as cable attachment and wrap plugs can be specified.

Stop Test Stops a looping test. Depending on the length of each test loop, this could take up to a minute.

Loop Test - stop on first error This starts a looping test that will stop when the first error is detected. A menu of additional test options may be presented before the loop is started.

Loop Test - Log all errors This starts a looping test that will loop until a \"Stop Test\" request is made. All detected errors are logged. A menu of additional test options may be presented before the loop is started.

View Test History Log Displays a history of recent diagnostic tests that have been executed.

View Hardware Error Log

Displays a list of errors detected by diagnostic tests.

- 5** Type **E** and press **Enter** to exit the diagnostic menus and return to the command line interface prompt (*).

Testing the Adapters

These tests for the adapters help to determine whether or not the adapter is functioning correctly. Most of the adapters (for example, the EIA 232, X.21, V.35/36, ESCON, and HSSI) contain basic testing functions; however, other adapters may have additional tests such as wrap plug and cable tests. The ESCON adapter also has optical power (page 5-16) and light reception tests (page 5-12).

Complete the following steps to test a faulty (or newly installed) Adapter:

- Power on the IBM 2216.
- Run diagnostics on the new adapter (page 5-9)
- If you have an ESCON adapter, run the light test on the new fiber optic cable (page 5-12).

Refer to “Overview of Diagnostic Functions and Status Information” on page 5-1 for additional information on the use of IBM 2216 operational diagnostics.

Powering On the IBM 2216

- 1** Power on the IBM 2216. Messages equivalent to the following appear on the TTY console after powering on the IBM 2216.

```
PRESENCE_MGR> LIC280 detected in slot 1
PRESENCE_MGR> LIC287 detected in slot 3
PRESENCE_MGR> LIC287 detected in slot 4

Please press the space bar to obtain the console.

Disk Load: Using bank B and config number 3
```

- 2** Press the space bar.

```
Console granted to this interface

*
```

Note: The operator interface described in this chapter is the *Command Line Interface*, also known as the *Operator Control Module (OPCON)*. This interface appears when you Telnet into the service port of the IBM 2216 or when you attach an ASCII terminal emulator to the service port either remotely or locally.

Running Diagnostics on the Adapter

The following is a sample sequence with sample screens for running the diagnostics. The selections that you see during your test may be different.

Before running the test, disable the adapter (see “Suspend Traffic on an Adapter Port” on page F-7).

- 1** At the OPCON (*) prompt, type **diags** and press **Enter**.
- 2** The Diagnostic Menu (see Figure 5-1 on page 5-2) appears. To make a selection type in the number of your choice and press **Enter**.
- 3** Type **1** and press **Enter** to access the Device List Page.
- 4** Select a device to test (for example, type **4** for ESCON) to test the ESCON channel adapter in slot 4.
- 5** Select **Run Interactive Test**. The Test Options menu appears:

```

                                Test Options                                Screen 1 of 1
LIC 287 - ESCON Channel Adapter, Slot 4
Operational Status  Diagnostic Status  Fault Status  Network Connection
NOT CONFIGURED      MESSAGE          UNKNOWN      UNKNOWN

Do not remove this device while testing.
Select one of the following test options:
* < 1. Run all tests excluding external wrap test >
* < 2. Run all tests including external wrap test >
  Individual tests:
* < 3. PCI BUS >
* < 4. PROCESSOR >
* < 5. MEMORY >
* < 6. MEMORY PROT >
* < 7. TIMER >
* < 8. AIB >
* < 9. WRAP PLUG >
* <10. OPTICAL POWER >
* <11. LIGHT RECEPTION >

Select (1-11 or B=Back R=Refresh H=Help ):2

```

Testing the Adapters

- 6** Type **2** and press **Enter** to run all tests including external wrap test. The following panel appears:

```
Screen 1 of 1
Setup For Wrap Test
LIC 287 - ESCON Channel Adapter, Slot 4
Operational Status Diagnostic Status Fault Status Network Connection
NOT CONFIGURED TESTING UNKNOWN UNKNOWN
Do not remove this device while testing.
Install the wrap plug (PN 5605670) on the ESCON adapter located in slot 4
Confirm that the wrap plug is installed.
< 1. Start test. >
Select (1 or B=Back R=Refresh H=Help ):1
```

- 7** Label and disconnect the cable for the adapter. Attach the wrap plug. Type **1** and press **Enter** to start the test.

This is a long-running test. The Device Status and Control Menu is displayed again. Note that the Diagnostic Status is TESTING. This indicates that the tests are running and will take about 3 minutes to complete.

```
Screen 1 of 1
Device Status and Control Menu
LIC 287 - ESCON Channel Adapter, Slot 4
Operational Status Diagnostic Status Fault Status Network Connection
NOT CONFIGURED TESTING UNKNOWN UNKNOWN
Do not remove this device while testing.
Select from the following:
  Disable Device
  Enable Device
  Run Default Test
  Run Interactive Test
  Loop Test - stop on first error
  Loop Test - Log all errors
  Stop Looping Test
  < 1. View Test History Log >
  < 2. View Hardware Error Log >
Select (1-2 or B=Back R=Refresh H=Help ):r
```

- 8** Type **r** and press **Enter** to refresh the display until the Diagnostic Status changes from TESTING to MESSAGE. At this point, the following panel is displayed:

```

                                Restore From Wrap Test                               Screen 1 of 1
LIC 287 - ESCON Channel Adapter, Slot 4
Operational Status  Diagnostic Status  Fault Status  Network Connection
  NOT CONFIGURED      MESSAGE           UNKNOWN       UNKNOWN

Do not remove this device while testing.

Remove the wrap plug on the ESCON adapter located in slot 4.

Reattach the fiber connection.

Select Back to see the results of the test.
Select ( B=Back R=Refresh H=Help ):b
    
```

- 9** Remove the wrap plug.
- 10** Reconnect the network cable to the adapter.
- 11** Select **b** to view the results of the test. In this example, the system reports test completion with No Errors. If the test fails, you will receive a message directing further action.

```

                                Test Results                                       Screen 1 of 1
LIC 287 - ESCON Channel Adapter, Slot 4
Operational Status  Diagnostic Status  Fault Status  Network Connection
  NOT CONFIGURED      INACTIVE           OK            UNKNOWN

The Test Completed with No Errors.

Select ( B=Back ): b
    
```

- 12** Select **b** to return to the Device Status and Controls Menu.

ESCON-only Tests

Run the Light Test on the New Fiber Optic Cable

After you have run diagnostics on the new ESCON adapter and verified that it is functioning correctly, you can test that the fiber optic cable is connected correctly and transmitting light to the adapter.

- 1 From the Device Status and Controls Menu, select Run Interactive Test to display the Test Options panel.

```

                                     Screen 1 of 1
                               Test Options
LIC 287 - ESCON Channel Adapter, Slot 4
Operational Status  Diagnostic Status  Fault Status  Network Connection
NOT CONFIGURED      MESSAGE           OK             UNKNOWN
Do not remove this device while testing.
Select one of the following test options:
* < 1. Run all tests excluding external wrap test >
* < 2. Run all tests including external wrap test >
  Individual tests:
* < 3. PCI BUS >
* < 4. PROCESSOR >
* < 5. MEMORY >
* < 6. MEMORY PROT >
* < 7. TIMER >
* < 8. AIB >
* < 9. WRAP PLUG >
* <10. OPTICAL POWER >
* <11. LIGHT RECEPTION >
Select (1-11 or  B=Back R=Refresh H=Help ):11
```

- 2 Enter 11 on the Test Options Panel to run the light reception test. At this point, the following panel appears.

```

                                     Screen 1 of 1
                               Setup For Light Reception Test
LIC 287 - ESCON Channel Adapter, Slot 4, Net # 0
Operational Status  Diagnostic Status  Fault Status  Network Connection
NOT CONFIGURED      TESTING           OK             UNKNOWN
First, be sure that you have successfully run the Wrap Plug Test on slot 4.
Then, remove the wrap plug from the ESCON adapter
(if still installed).
Connect the fiber for an operational ESCON channel to the adapter located in
slot 4.
Confirm that the correct fiber is installed.
< 1. Start test. >
Select (1 or  B=Back R=Refresh H=Help ):1
```

- 3** Install the fiber, then enter **1** to start the test. Because this is a “long running test,” the Device Status and Control Menu will be displayed again. Notice that the Diagnostic Status is TESTING. This indicates that the test is now running and will take about 20 seconds to complete.

```

                                                                 Screen 1 of 1
                        Device Status and Control Menu

LIC 287 - ESCON Channel Adapter, Slot 4, Net # 0

Operational Status  Diagnostic Status  Fault Status  Network Connection
      NOT CONFIGURED      TESTING          OK             UNKNOWN

Do not remove this device while testing.

Select from the following:
  Disable Device
  Enable Device
  Run Default Test
  Run Interactive Test
  Loop Test - stop on first error
  Loop Test - Log all errors
  Stop Looping Test
  < 1. View Test History Log >
  < 2. View Hardware Error Log >

Select (1-2 or  B=Back R=Refresh H=Help ):r
```

- 4** After the message Diagnostic Test for **adapter x** has status available appears, select **Refresh** to show the status information for a device. At this point, the following panel is displayed.

```

                                                                 Screen 1 of 1
                        Restore From Light Reception Test

LIC 287 - ESCON Channel Adapter, Slot 4, Net # 0

Operational Status  Diagnostic Status  Fault Status  Network Connection
      NOT CONFIGURED      MESSAGE          OK             UNKNOWN

Do not remove this device while testing.

Leave the fiber connected to the ESCON adapter located in slot 4
if it is the fiber intended for this adapter.

If it is not the fiber intended for this adapter,
connect the correct fiber now.

Select Back to see the results of the test.

Select (  B=Back R=Refresh H=Help ):b
```

- 5** Typically, you do not need to do anything here. If you are testing cables, this simply tells you that the test has completed and that you should ensure that the correct fiber is connected.

6 Select **b** to see the results of the test.

```
Test Results                                     Screen 1 of 1
LIC 287 - ESCON Channel Adapter, Slot 4, Net # 0
Operational Status  Diagnostic Status  Fault Status  Network Connection
NOT CONFIGURED     INACTIVE     OK           UNKNOWN
The Test Completed with No Errors.

Select ( B=Back ):
```

If the test completed with no errors, light was detected on the fiber optic cable.

```
Test Results                                     Screen 1 of 1
LIC 287 - ESCON Channel Adapter, Slot 4, Net # 0
Operational Status  Diagnostic Status  Fault Status  Network Connection
NOT CONFIGURED     INACTIVE     NON-ISOLATED UNKNOWN
No light is being detected on the ESCON adapter in slot 4. Ensure that the
ESCON fiber is connected to an ESCON director or an ESCON channel.

Select ( B=Back ):e
```

If light was not detected, an error message is displayed, indicating that the fiber and its connections need to be rechecked.

ESCON Interactive Test Options

The Test Options menu is displayed in response to a Run Interactive Test request on the Device Status and Control Menu. Both test suites and individual tests are available to allow you to examine the entire adapter or isolate its various components.

```

                                     Screen 1 of 1
                               Test Options

LIC 287 - ESCON Channel Adapter, Slot 4, Net # 0

Operational Status  Diagnostic Status  Fault Status  Network Connection
      DISABLED           MESSAGE           UNKNOWN           UNKNOWN

Do not remove this device while testing.
Select one of the following test options:
* < 1. Run all tests excluding external wrap test >
* < 2. Run all tests including external wrap test >
  Individual tests:
* < 3. PCI BUS >
* < 4. PROCESSOR >
* < 5. MEMORY >
* < 6. MEMORY PROT >
* < 7. TIMER >
* < 8. AIB >
* < 9. WRAP PLUG >
* <10. OPTICAL POWER >
* <11. LIGHT RECEPTION >

Select (1-11 or B=Back R=Refresh H=Help ):
```

Option 1 on the Test Options menu runs tests 3 through 8. Option 2 runs the first test set and the wrap test. The remaining options, 3 to 11, enable the execution of tests individually.

If you select option 3, 4, 6, or 7, the results will be displayed immediately.

If you select test option 1, 2, 5, 8, 9, or 11 (all long-running tests) the result may not be available for a few minutes. In this case, the test will continue to run and the Device Status and Control Menu will be displayed again.

If you select option 1, 2, 5, 8, 9, or 11, you will also notice that the Operational Status field indicates "TESTING." In these instances, you will need to refresh the panel until the system displays your test results. Option 10 is also a long-running test, but selection of this option does not invoke the Device Status and Control Menu. Instead, the system displays a panel that allows you to end the test at your convenience.

The individual tests are the same tests that run as part of the default tests. However, there are a few additional tests that are available only from the Test Options menu. They are:

Wrap plug

Option 9 runs the AIB test unit and an optical (external) wrap test. The wrap test requires that the fiber be removed and a wrap plug be installed. For an example of using this function, see "Testing the Adapters" on page 5-8.

Optical power	Option 10 runs the AIB test unit and allows you to measure the optical output of the adapter. This test requires that the fiber be removed and an optical power meter be attached. See “ESCON Optical Power Measurement Test” on page 5-16 for additional information.
Light reception	Option 11 runs the AIB test unit and also tests whether the attached fiber is transmitting light. This test can be used to determine if the remote end of the fiber is connected. For an example of using this function, see “Testing the Adapters” on page 5-8.

ESCON Optical Power Measurement Test

The following example describes the use of option **10**, Optical Power.

Enter **10** on the Test Options panel to run the optical power meter test.

```

                                     Test Options                               Screen 1 of 1
LIC 287 - ESCON Channel Adapter, Slot 4, Net # 0
Operational Status  Diagnostic Status  Fault Status  Network Connection
      DISABLED           MESSAGE           UNKNOWN           UNKNOWN

Do not remove this device while testing.
Select one of the following test options:
* < 1. Run all tests excluding external wrap test >
* < 2. Run all tests including external wrap test >
  Individual tests:
* < 3. PCI BUS >
* < 4. PROCESSOR >
* < 5. MEMORY >
* < 6. MEMORY PROT >
* < 7. TIMER >
* < 8. AIB >
* < 9. WRAP PLUG >
* <10. OPTICAL POWER >
* <11. LIGHT RECEPTION >

Select (1-11 or B=Back R=Refresh H=Help ):10

```

The optical power measurement test verifies that the ESCON channel adapter in the slot indicated is operating correctly and that the receive input level is within tolerance.

This test assumes that you have the following equipment installed:

- Optical Power Meter
- Duplex-to-Duplex Coupler
- Duplex-to-Biconic Test Cable

If you do not have the correct equipment, or wish to bypass this test, reinstall the fiber (if you removed it) and select **B** to return.

Using the materials previously listed to complete the test, perform the following steps:

- 1** Ensure that the black cap is over the biconic receptacle at the top of the power meter.
- 2** Press power On/Off. AUTO OFF appears on the display.

3 Allow a 2-minute warmup. The meter turns off if you do not press a button within 10 minutes.

4 If the meter does not display **Optical Power Meter**, repeatedly press the lambda pushbutton until 1300 nm appears.

Note: To ensure that the pushbutton produces the desired results, do not hold down the pushbutton for more than half a second.

5 Press Zero. The following two displays appear:

- A value between 0.30 and 0.70 nanowatts (nW)
- After a short time **0** blinks, indicating that the meter is correctly zeroed.

If the meter is not correctly zeroed, a Hi or Lo is displayed after you press Zero. Press Zero again, and using a jeweler's screwdriver, adjust the trim pot that is beside the biconic receptacle at the top of the meter until a value between 0.30 and 0.70 nW is displayed. Set the value to 0.50, if possible.

6 Press Zero again to zero the meter.

The meter must also display dBm. If nW is displayed, press dBm/Watt. The optical power meter is now set.

7 After you set the meter, connect the black biconic connector of the test cable to the biconic receptacle on top of the power meter.

8 Enter **1** to start the test as indicated in the following example.

```

                                     Setup For Optical Test                               Screen 1 of 1
LIC 287 - ESCON Channel Adapter, Slot 4, Net # 0
Operational Status  Diagnostic Status  Fault Status  Network Connection
DISABLED            TESTING           UNKNOWN      UNKNOWN
Do not remove this device while testing.
Install the duplex-to-biconic test cable connector to the ESCON
channel adapter located in slot 4.
Set the optical power meter to the following options:
* -- Power turned on
* -- Set for 1300 nanometers (nm)
* -- Zeroed
* -- The decibel scale displayed (dBm)
Confirm the meter is set.
< 1. Start > the adapter transmitter.
Select (1 or B=Back R=Refresh H=Help ):1
```

The green port LED on the 2216 ESCON Adapter will start blinking once the adapter has started transmitting the idle sequences. At this point, record the signal level displayed on the power meter. A correctly functioning 2216 ESCON adapter should have a power level of -21.0 dBm or more (for example, -18.0 dBm).

9 Replace the ESCON Channel Adapter if its power level is too low.

10 Enter 1 from the Optical Test in Progress panel to Stop the test.

```

                                     Optical Test In Progress
                                     Screen 1 of 1

LIC 287 - ESCON Channel Adapter, Slot 4, Net # 0

Operational Status  Diagnostic Status  Fault Status  Network Connection
      DISABLED           TESTING           UNKNOWN           UNKNOWN

Do not remove this device while testing.

The green PORT LED should now be flashing on the ESCON channel
adapter in slot 4, indicating that it is transmitting IDLE sequences.
You may now record the power level displayed on the optical power meter
A properly functioning ESCON should have a power level of -21.0dBm or more
(for example -18.0dBm).

Select < 1. Stop > test when you have finished
measuring the signal level.

Select (1 or  B=Back R=Refresh H=Help ): 1

```

11 The following Test Results panel is displayed when you stop the test.

```

                                     Test Results
                                     Screen 1 of 1

LIC 287 - ESCON Channel Adapter, Slot 4, Net # 0

Operational Status  Diagnostic Status  Fault Status  Network Connection
      DISABLED           INACTIVE           OK           UNKNOWN

The Test Completed with No Errors.

Select ( B=Back ):

```

Appendix A. Hardware Error Codes

The error log that is displayed when you use the Displaying the Error Log firmware utility (see “Displaying the Error Log” on page 4-16) contains error codes. This appendix contains explanations for those error codes.

Error Code	Physical Location	Software Subsystem	Explanation
00010000	Processor	Processor	Processor test failure
00011000	PPC Board	NVRAM	128-KB Non-volatile RAM test failure
00015001	PPC Board	Flash	An error occurred while erasing the system firmware.
00015002	PPC Board	Flash	An error occurred while updating the system firmware.
00015500	PPC Board	Interrupts	PPC board interrupt test failure.
00015501	PPC Board	Interrupts	Interrupt test of the processor's timing register failed.
00015502	PPC Board	Interrupts	Interrupt test of the PPC board clock failed.
00015503	PPC Board	Interrupts	Interrupt test of the PPC board programmable timer failed.
00016002	PPC Board	RTC-NVRAM	Read/Write test failure for PPC board clock.
00017001	PPC Board	Security	CMOS battery drained. Replace RTC/8KB NVRAM.
00017002	PPC Board	Security	CMOS Error—data is gone. Replace RTC/8KB NVRAM.
00017003	PPC Board	Security	Power Interruption during last boot sequence update.
00017007	PPC Board	Security	Maximum unsuccessful attempts to enter password was reached. Time and date are logged.
00020000	Memory	Memory	Memory test error; run further tests.
000210y0	SIMM slot y	Memory	Memory error with SIMM slot y (where y=1 or 2); 1=U13 2=U14.
01291000	L2 Cache	L2 Cache	For later release
1msceddd	PPC Board	Octal Uart	Octal Uart error.
2msceddd	PPC Board	I ² C	I ² C controller, bus, or device error
3msceddd	PPC Board	GCOM	GCOM controller error
30002000	System Card	—	Hard disk error. Format hard disk.
5msceddd	PPC Board	PCMCIA	PCMCIA controller error
50000000	PPC Board	PCMCIA	PCMCIA controller error
80001300	—	Flash	Firmware update file is at the same level as current firmware. Update canceled.
80001400	—	Flash	Firmware update file does not support this system. Update canceled.
80001500	—	Flash	The firmware update file is corrupted. Update canceled.
80001600	—	Flash	The firmware update file is corrupted. Update canceled.
80001700	—	Flash	See 80001500.
80001700	—	Flash	See 80001500.
80001800	—	Flash	A valid firmware update file cannot be located. Update canceled.
80001900	—	Flash	See 80001500.
80002100	—	Flash	The firmware update file cannot be loaded. Update canceled.
80002400	—	Flash	See 80001400
80002500	—	Flash	See 80001400
90001600	—	Copy Utility	Not enough VDISK space. Unable to copy files.

Appendix B. Parts Listing

This parts listing contains reference drawings and a corresponding index for all field-replaceable parts. The index provides the part number, the quantity required (units), and a description of the part.

The following list provides additional information about the parts assembly index.

SIMILAR ASSEMBLIES: If two assemblies contain a majority of identical parts, they are broken down on the same list. Common parts are shown by one index number. Parts specific to one or the other of the assemblies are listed separately and identified by description.

AR: (As Required) in the Units column indicates that the quantity is not the same for all machines.

NP: (Non-Procurable) in the Units column indicates that the part is non-procurable and that the individual parts or the next higher assembly should be ordered.

NR: (Not Recommended) in the Units column indicates that the part is procurable but not recommended for field replacement, and that the next higher assembly should be ordered.

R: (Restricted) in the Units column indicates that the part has a restricted availability.

INDENTURE: The indenture is marked by a series of dots located before the parts description. The indenture indicates the relationship of a part to the next higher assembly. For example:

Indenture	Relationship of Parts
(No dot)	MAIN ASSEMBLY
(One dot)	• Detail parts of a main assembly
(One dot)	• Subassembly of the main assembly
(Two dot)	• • Detail part of a one-dot subassembly
(Two dot)	• • Subassembly of a one-dot subassembly
(Three dots)	• • • Detail part of a two-dot subassembly

Assembly 1: Final Assembly, 2216 - Model 400

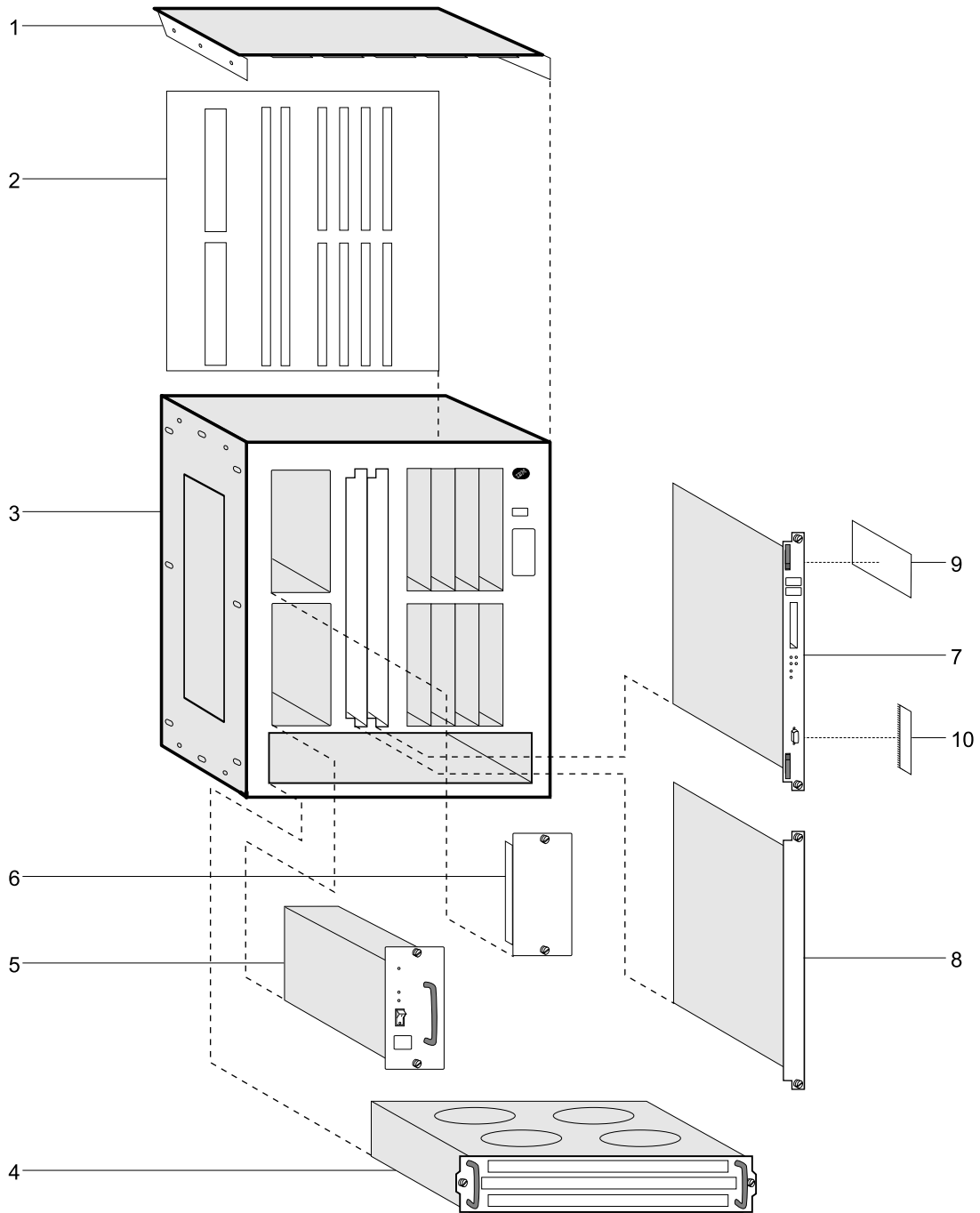

Asm- Index	Part Number	Units	Description
1-		NP	Final Assembly
-1	13H4931	1	• Cover, Top
-2	85H7860	1	• Backplane 2216-400
-3	72H5099	1	• Enclosure
-4	85H6840	1	• Fan Tray Assembly
-5	72H5081	1	• Power Supply -- FC 2871
-6	41H7701	1	• Power Supply Filler Plate
-7	85H7916	1	• System Card (release 1)-- FC 2851
-	85H9682	1	• System Card (release 2)-- FC 2855
-8	72H5101	1	• Filler Plate
-9	39H2221	1	• Hard Drive (IDE 1.08G Hardfile)
-	85H7917	1	• Hard Drive (1.6GB 2.5" Hardfile)
-10	85H9688	1	• 64-MB DIMM memory
-20	02L1873	1	• LIC 280 (Not Illustrated) 2 Port Token Ring -- FC 2280
-	02L1872	1	• LIC 281 (Not Illustrated) 2 Port Ethernet -- FC 2281
-	85H4872	1	• LIC 282 (Not Illustrated) 8 Port RS-232 -- FC 2282
-	02L2065	1	• LIC 283 (Not Illustrated) 1 Port ISDN Pri (T1) -- FC 2283
-	85H4894	1	• LIC 284 (Not Illustrated) 1 Port 155Mbps (MMF ATM) -- FC 2284
-	86H0967	1	• LIC 286 (Not Illustrated) 1 Port FDDI
-	85H4878	1	• LIC 287 (Not Illustrated) 1 Port ESCON Channel -- FC 2287
-	86H1005	1	• LIC 288 (Not Illustrated) 1 Port 10/100 Mbps Ethernet -- FC 2288
-	85H9703	1	• LIC 289 (Not Illustrated) 1 Port HSSI -- FC 2289
-	85H4874	1	• LIC 290 (Not Illustrated) 6 Port V.35/V.36) -- FC 2290
-	85H4876	1	• LIC 291 (Not Illustrated) 8 Port X.21 -- FC 2291
-	02L2066	1	• LIC 292 (Not Illustrated) 1 Port ISDN Pri (E1) -- FC 2292
-	85H6834	1	• LIC 293 (Not Illustrated) 1 Port 155Mbps (SMF ATM) -- FC 2293
-	86H0986	1	• LIC 294 (Not Illustrated) 1 Port 155Mbps (MMF ATM) -- FC 2294
-	86H0993	1	• LIC 295 (Not Illustrated) 1 Port 155Mbps (SMF ATM) -- FC 2295
-25	85H7923	1	• Wrap Plug Service Kit 2216-400 (Not Illustrated) -- FC 2505 (see 1-14 for a list of contents)

2216-400 Feature Codes

NAME	FRU P/N	FEATURE CODE	DESCRIPTION
Modem	- 85H3549	-- FC 2900	-- US/Canada PCMCIA MODEM
Modem	- 85H3550	-- FC 2901	-- Austria PCMCIA MODEM
Modem	- 85H3551	-- FC 2902	-- Australia PCMCIA MODEM
Modem	- 85H3552	-- FC 2903	-- Belgium PCMCIA MODEM
Modem	- 85H3553	-- FC 2904	-- Denmark PCMCIA MODEM
Modem	- 85H3554	-- FC 2905	-- Finland PCMCIA MODEM
Modem	- 85H3555	-- FC 2906	-- France PCMCIA MODEM
Modem	- 85H3556	-- FC 2907	-- Germany PCMCIA MODEM
Modem	- 85H3557	-- FC 2908	-- Hong Kong PCMCIA MODEM
Modem	- 85H3558	-- FC 2909	-- Ireland PCMCIA MODEM
Modem	- 85H3559	-- FC 2910	-- Italy PCMCIA MODEM
Modem	- 85H3560	-- FC 2911	-- Japan PCMCIA MODEM
Modem	- 85H3561	-- FC 2912	-- Korea PCMCIA MODEM
Modem	- 85H3562	-- FC 2913	-- Luxemburg PCMCIA MODEM
Modem	- 85H3563	-- FC 2914	-- Netherland PCMCIA MODEM
Modem	- 85H3564	-- FC 2915	-- New Zealand PCMCIA MODEM
Modem	- 85H3565	-- FC 2916	-- Norway PCMCIA MODEM
Modem	- 85H3569	-- FC 2921	-- Sweden PCMCIA MODEM
Modem	- 85H3570	-- FC 2922	-- Switzerland PCMCIA MODEM
Modem	- 85H3571	-- FC 2925	-- UK PCMCIA MODEM
Modem	- 85H6839	-- FC 2927	-- Israel PCMCIA MODEM
Cable	- 85H3589	-- none	-- Modem Cable

Figure B-1.

2216 Feature Card Cables

P/N	RELEASE 1 2216-400 CABLES	FEATURE
71G3497	LIC 282 EIA-232/V.24 FANOUT CABLE	FC 2701
72F0165	LIC 290 V.35 FANOUT CABLE	FC 2702
73H2507	LIC 290 V.36 FANOUT CABLE	FC 2703
06H4648	LIC 291 X.21 FANOUT CABLE	FC 2704
38H7071	LIC 282 EIA-232/V.24 SERIAL INTERFACE	FC 2705
59G7195	LIC 282 EIA-232/V.24 DIRECT ATTACH	FC 2706
11H4958	LIC 290 V.35 SERIAL INTERFACE	FC 2707
38H7075	LIC 290 V.35 DIRECT ATTACH	FC 2708
38H7079	LIC 290 V.36 SERIAL INTERFACE	FC 2709
38H7077	LIC 290 V.36 DIRECT ATTACH	FC 2710
38H7070	LIC 291 X.21 SERIAL INTERFACE	FC 2711
38H7073	LIC 291 X.21 DIRECT ATTACH	FC 2712
41H9082	MULTIPURPOSE RJ-45 STP CABLE	FC 2713
85H3509	LIC 283 ISDN PRI CABLE (T1)	FC 2714
80G3984	LIC 292 ISDN PRI CABLE (E1)	FC 2715
57G8042	LIC 283 ISDN PRI CABLE (J1)	FC 2716
	V.35 SERIAL CABLES - FRANCE	FC 2799
1749352	V.35 SERIAL INTERFACE EXTENSION CABLE	
11H4958	V.35 SERIAL INTERFACE CABLE	
86H0971	LIC 289 HSSI DTE/DCE CABLE	(no feature codes)
86H0970	LIC 289 HSSI Null Modem CABLE	

Figure B-2.

Appendix C. Hardware Characteristics

Physical Specifications

The dimensions of the IBM 2216 are as follows:

Width

440 mm (17.3 in.) without rack mounting flange
480 mm (18.9 in.) with rack mounting flange

Depth

358 mm (14.1 in.)

Height

572 mm (22.5 in.) (13U) without rubber feet pads
576.1 mm (22.7 in.) (13U) with rubber feet pads

Weight

The base box of the IBM 2216 (with one power supply), system card, no adapters, a power supply filler plate, and no adapter filler plates weighs 31.6 kg (69.7 lb).

- Each adapter weighs approximately 1 kg (2.2 lb).
- Each filler plate for an unoccupied adapter slot weighs 0.1 kg (0.2 lb).
- A filler plate for a second power supply weighs 0.2 kg (0.4 lb)
- A second power supply weighs 3.5 kg (7.7 lb).

A fully populated IBM 2216 with a second power supply and eight adapters will weigh about 43.1 kg (95 lb).

Note: During installation, two people will be required to lift the 2216.

Service Clearances

You must leave free space for service around the machine as follows:

Front 750 mm (30 in.)
Sides No clearance required
Rear No clearance required

Airflow

A multiple-fan (forced air) ventilation system is installed in each unit. The airflow is 2.0 cubic meters per minute (71 cubic feet per minute).

Operating Environment

Temperature 10°C to 40.6°C (50°F to 105°F)
Relative Humidity 8% to 80%
Max Wet Bulb 27°C (80°F)

Lightning Protection

The power supplies of the IBM 2216 are protected against lightning.

Contact an electrical contractor to determine if lightning protection is needed for your power distribution system.

Electromagnetic Interference

The IBM 2216 is compatible with the following classes of interference:

- Federal Communication Commission (FCC), Part 15, Subpart J, class A (USA)
- Comité International Spécial des Perturbations Radioélectriques (CISPR) Publication 22, Class A
- General Operating Permit (GOP) (Germany)
- Voluntary Control Council for Interference (VCCI) Class 1 and IEC 1000-3-2 (Japan)

Power Supply

The IBM 2216 can have one or two power supplies. A single power supply can provide power for a fully configured unit. The first power supply will remain fully operational while a second is either being installed or removed. The second power supply must have its power switch in the off position while it is being installed or removed. If a second power supply is not installed, a filler plate is used to cover the position where it would have been installed.

The power supply uses a voltage sensing system that converts line current of 100—240 volts ac, 50/60 Hz single-phase, to dc input as required by the system card, the adapters, and the fan tray.

Power Supply Requirements

For the IBM 2216, the ac power source must be able to supply:

- 100 to 240 V ac (nominal voltage)
- 50 or 60 Hz
- Single phase
- 0.62 kVA power
- 70 amps peak inrush current for one quarter cycle per supply

Power Cord Characteristics

The ac power cord is supplied with a country-dependent plug. For each of the cords listed in Table C-1, find its plug type in Figure C-1 on page C-4 by comparing *index* numbers. (The index number is displayed below each plug type in Figure C-1.)

Table C-1. Power Cords and Power Plug Standards

Index	Part Number	Feature Code	Countries	Power Cord	Plug Standard
1	1838574	9833	Canada, Japan, Philippines, Taiwan, Thailand, Bolivia, Brazil, Ecuador, Peru, Venezuela, United States	250 V, 10 A, 2.7 m (9 ft)	NEMA WD-1 6-15P
2	6952300	9810	United States (except Chicago), Puerto Rico, Canada, Japan, South Korea, Philippines, Taiwan, Saudi Arabia, Mexico, Bolivia, Brazil, Colombia, Ecuador, Peru, Venezuela, Panama	125 V, 10 A, 2.7 m (9 ft)	NEMA WD-1 5-15P
2	6952301	9815	United States (Chicago only)	125 V, 10 A, 1.8 m (6 ft)	NEMA WD-1 5-15P
2	1838576	9818	United States (Chicago only)	250 V, 10 A, 1.8 m (6 ft)	NEMA WD-1 5-15P
3	13F9979	9820	Indonesia, South Korea, Macau, Austria, Belgium, Finland, France, Germany, Greece, Norway, Portugal, Saudi Arabia, Spain, Sweden, Turkey, Netherlands, China, Brazil	250 V, 10 A, 2.7 m (9 ft)	CEE7 VII
4	14F0033	9825	Brunei, China, Hong Kong, India, Malaysia, Singapore, Ireland, Kuwait, United Arab Emirates, United Kingdom	250 V, 10 A, 2.7 m (9 ft)	BS 1363
5	14F0051	9828	Switzerland, Liechtenstein	250 V, 10 A, 2.7 m (9 ft)	SEV 24507
6	14F0069	9830	Italy, Chile	250 V, 10 A, 2.7 m (9 ft)	CEI 23-16
7	13F9997	9821	Denmark	250 V, 10 A, 2.7 m (9 ft)	Normblad 4
8	14F0087	9827	Israel	250 V, 10 A, 2.7 m (9 ft)	SII-32-1971
9	13F9940	9831	Australia, New Zealand, Argentina, China	250 V, 10 A, 2.7 m (9 ft)	AS 3122-1981 NZS 198
9	6952291	9834	Argentina, Colombia, Brazil, Paraguay, Uruguay	250 V, 10 A, 2.7 m (9 ft)	IEC 83-A5 1957
10	14F0015	9829	Bangladesh, Myanmar, Sri Lanka, Pakistan, South Africa	250 V, 10 A, 2.7 m (9 ft)	SABS 164 BS 546

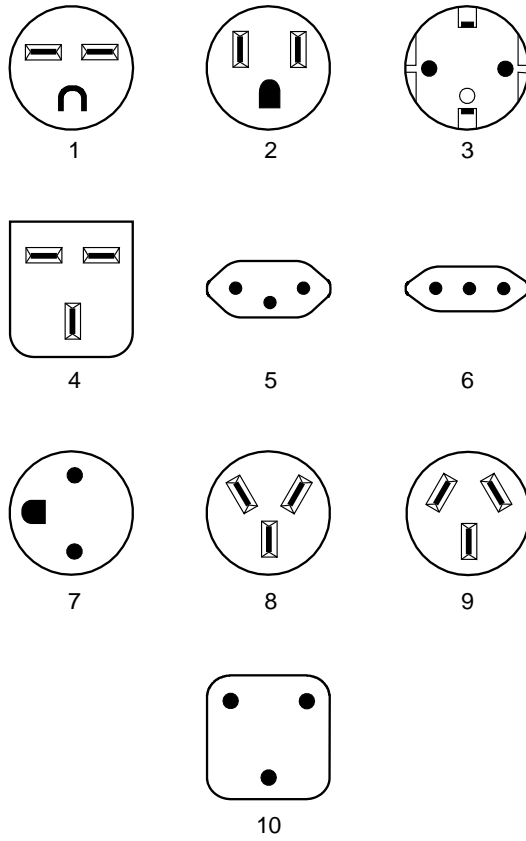

Figure C-1. Power Cord Plugs by Country

Appendix D. Managing Operational Code and Configuration Files

This chapter explains how to manage the operation code images and configuration files.

Reconfiguring

You might find it hard to detect problems caused by configuration errors. A configuration error can initially appear to be a hardware problem because the 2216 will not start or data will not flow through a port. In addition, problems with configuration may not result in an error initially; an error may occur only when specific conditions are encountered or when heavy network traffic occurs.

If you cannot resolve a problem after making a few changes to your configuration or after restoring the active configuration file, it is recommended that you generate a new configuration. Too many changes to a configuration often compound the problem, whereas you can usually generate and test a new configuration within a few hours.

How Software Files Are Managed

To help you manage operational software upgrades and configurations, the IBM 2216 has a software change management feature. This utility enables you to determine which operational software file and which configuration file is active while the IBM 2216 is running.

How to View the Files

To use the change management tool in the command line interface to view the operational software image and the configuration files, follow these steps:

1. From the OPCON prompt, which is an asterisk (*), type **talk 6** and press **Enter**. The `Config>` prompt appears.
2. Type **boot** and press **Enter**. You will see the prompt `Boot config>`.
3. Type **list** and press **Enter**. You will see a list similar to this one:

```
Boot config> list

BANK A                               BANK B
IMAGE - ACTIVE                       IMAGE - AVAIL
CONFIG 1 - ACTIVE                    CONFIG 1 - AVAIL
CONFIG 2 - AVAIL                     CONFIG 2 - AVAIL
CONFIG 3 - NONE                      CONFIG 3 - NONE
CONFIG 4 - NONE                      CONFIG 4 - NONE
```

Each bank represents one image of the operational code. The images stored in BANK A and BANK B are stored on the hard drive. The Configs represent the configuration files that are stored with each bank. *IMAGE* refers to the status of the operational software and *CONFIG* refers to the status of the configuration files.

The possible IMAGE and CONFIG status:

ACTIVE	This file is currently loaded in active memory and is running on the IBM 2216. Note: The status of this file can be changed only by resetting the IBM 2216. <i>If a config or an image is active, it is locked and cannot be overwritten or erased.</i>
AVAIL	This is a good file that can be made active.
CORRUPT	This file was damaged or was not loaded into the IBM 2216 completely.
PENDING	This file will be loaded and become active the next time the IBM 2216 is reset.
LOCAL	This file will become active at the next reset. This reset will cause the currently ACTIVE file to become PENDING. LOCAL is a status that makes a file ACTIVE only for one reset of the IBM 2216.

Only one bank at a time contains an ACTIVE image. Only one configuration file is ACTIVE and it must be within the ACTIVE bank.

How to Reset the IBM 2216

Attention: A reset interrupts the function of the IBM 2216 for up to 90 seconds. Be sure that the network is prepared for the interruption.

As previously stated, PENDING and LOCAL files are not loaded into active memory until you reset the IBM 2216.

You can reset the IBM 2216 using any one of these methods:

- Press the hardware reset on the system card.
- At the Config only> prompt, type **reload** and press **Enter**.

Note: The Config only> prompt appears when no file is active. Lack of an active file indicates that an active configuration has become corrupted or that the IBM 2216 is not configured.

- At the OPCON prompt (*), type **reload** and press **Enter**.

File Transfer Using TFTP

Use this sequence of commands to transfer a file from a workstation or server to the IBM 2216 using TFTP. You will need to substitute your own values for the IP address and path, which are given as examples. The number of bytes received is also an example.

Note: You transfer the files to banks within the IBM 2216. The banks represent the directories that you have created; you do not have to be concerned about transferring the files to a particular directory within the IBM 2216.

TFTP File Transfer using the Operating Software

Note: You cannot use the TFTP file transfer method in the operating software to migrate from Version 1 to Version 2 of the MAS code. (See "Migrating to a New Code Level" on page D-5 for migration directions which explicitly lead you through the firmware method to migrate to a new level of code.)

1 From the OPCON prompt, which is an asterisk (*), type **talk 6** and press **Enter**. The Config> prompt appears.

2 Type **boot** and press **Enter**. The Boot config> prompt is displayed.

3 To get the MAS software code load:

- Enter **tftp get load modules** (for MAS software Version 2 or above)
- Enter **tftp get load single image** (below MAS software Version 2).

To get a configuration file, enter **tftp get config**

You cannot overwrite a currently active bank image.

4 When prompted, specify the IP address of the TFTP server.

5 When prompted:

- Specify the path/file name for a single image
or
- Specify just the path for load modules

With Version 2, when you specify that you want load modules to transfer, all of the appropriate load modules in the specified directory will be transferred.

There could be up to 20 separate load modules. All the load modules must be in the same directory to enable the successful transfer of all the modules.

The following example shows a Version 2 software code load:

```
* talk 6
Config> boot
Boot config> tftp get load modules
Specify the server IP address (dotted decimal): [1.2.3.4] 192.9.200.1
Specify the remote files directory: (/u/bin/) /usr/601bin/204img/
Select the destination bank: (A,B): [A] a
TFTP SW load image
get: /usr/601bin/204img/LML.ld
from: 192.9.200.1
to: bank A.
```

Operation completed successfully.

TFTP File Transfer using the Firmware

1 From the main firmware menu (“Systems Management Services,” select (4. utilities)

2 From the “Systems Management Utilities” menu select (12. Change Management).

3 From the “Change Management Software Control” menu select (10. TFTP software).

Note: You must have setup your IP addresses on the devices before you can TFTP. (See section “Setting Up Remote Initial Program Load” on page 4-19 to setup IP parameters in the firmware.)

4 Select the type of software from the “Select Type” dialog box.

- 5 Select which bank from "Select Bank" dialog box
- 6 If you selected 2. Load Image, you will be prompted to select the type of load image (that is, single image or modules).
 - If the code load you want to transfer consists of an LML.Id file plus other load modules ending in .Id, select **modules**.
 - If you want to transfer a single image (the type that existed in MAS Version 1 Release 1), select **single image**.
- 7 When prompted, type in either the Directory Path to the modules, or for the path/filename for the single image. The modules should all be in one directory.
- 8 When prompted, select the medium for tftp. For example, you might have choices for PCMCIA, LIC adapters, and SLIP (depending on the adapters in your machine).
- 9 If you selected modules and the directory path you entered has all read permissions correct for 'anybody' to retrieve, you will see successive message boxes appear as each load module is transferred.

If you select single image, only one message box will appear to inform you of the file transfer.
- 10 Select the Set Boot Information option on the Change Management menu and select:
 - The Bank to boot from
 - The Config to boot with
 - Permanent or once

File Transfer Using Xmodem

If you use Xmodem, you will get similar prompts that enable you to specify the bank for the image files or the bank and the config number for the configuration files that you transfer. The interface for transferring is designed so that you cannot overwrite any ACTIVE file. (Xmodem is available only from the firmware.)

For transfers via modem, each load module must be separately named and transferred individually.

Note: When using Xmodem to transfer a multiple load module image (used in Version 2 in the form of several files ending in .Id), **you must** transfer each of the modules (.Id files) one by one to get the entire load module image.

When an entire load image has transferred, the status of the bank will change from CORRUPT to AVAIL. Transfer file LML.Id first. Unless you see an information message ERROR WRITING FILE appear, assume each individual transfer has been successful.

Migrating to a New Code Level

Notes:

1. In Version 1 Release 1 of the MAS, the lower level code does not have any enhanced ability to retrieve the new (Version 2) operating code levels. If you attempt to use the **talk 6** in the operating code, the file transfer attempt will be unsuccessful.
2. **You must use either the firmware tftp or Xmodem to get the new level of code.**

To upgrade from any earlier release of operational code to a later level, do the following:

- 1 Follow the instructions in “Updating System Firmware” on page 4-14 to update the system firmware to the Version 2 level.
- 2 After starting the Firmware, select the following sequence of menus:
 - Utilities menu
 - Change ManagementThen, select the TFTP Software option.
Note: You must have setup your IP addresses on the devices before you can TFTP. (See section “Setting Up Remote Initial Program Load” on page 4-19 to setup IP parameters in the firmware.)
- 3 Respond to the prompt to select which type of load to do (a configuration file or a load image).
- 4 Respond to the prompt to select which bank to load.
Note: Files to be retrieved from the server should all be in the same directory, and their permissions should be such that read is allowed for anybody.
- 5 After you selected **2. Load Image**, you will be prompted to select the type of load image (that is, single image or modules).
 - If the code load that you want to transfer consists of an LML.ld file plus other load modules ending in .ld, select **modules**.
- 6 When the prompt Enter Directory Path to Remote Load Modules appears, enter the *pathname* to retrieve all load modules belonging to this load image.
- 7 When prompted, select the medium to use for TFTP. Depending on the adapters in your 2216, there could be choices for PCMCIA, several adapters, and SLIP.
- 8 Information boxes appear as each load module is being transferred using TFTP. Some time will transpire as each transferred load module is written to the disk. An average load may take 10-12 minutes. When the entire load has been transferred, the previous menu is displayed.

The Version 2 operational code comes in the form of multiple load modules, headed by LML.ld.

- All load modules for a load must be in the same directory on the server for this transfer.

9 Select the Set Boot Information option on the Change Management menu and select:

- The Bank to boot from
- The Config to boot with
- Permanent or once

Once you have Version 2 operational code, you will be able to use the **tftp get load modules** option under `boot config>` to get any further load images.

If you were not able to use TFTP and instead use Xmodem to try to upgrade, select the Xmodem Software option instead of TFTP Software option. In the case of XMODEM file transfers, Xmodem does not retrieve a set of load modules. They must be transferred one by one.

Using the Configuration Program to Manage the Configuration Files

For optimal configuration management, it is recommended that you use the Configuration Program and its configuration database to manage all your IBM 2216 configuration files.

The design of change management facilitates good control of the configuration files. Keeping the ACTIVE file and the file that is stored in the configuration database the same assures that a copy of the ACTIVE file is always available.

When you use the Send option to send a new configuration to the IBM 2216, the new configuration is written to the ACTIVE bank and overwrites the file located in the position just below the currently ACTIVE configuration. The new configuration is PENDING if a time is set for a reset. If the configuration file is sent without a specified time for the reset to occur, it gets AVAIL status.

For example, suppose that CONFIG 2 is ACTIVE. The new configuration file is written to CONFIG 3. It has a status of PENDING if a reset time is associated with it; if not, it has a status of AVAIL.

If the file has a status of PENDING, CONFIG 2 becomes AVAIL and CONFIG 3 becomes ACTIVE when a reset occurs. The next file that is sent from the Configuration Program will be placed in CONFIG 4. If a reset time is associated with the file, it will have the PENDING status and will become ACTIVE when the next reset occurs. If another file is then sent, it is placed in CONFIG 1 because the currently ACTIVE file is now in CONFIG 4. This arrangement results in a circular queue.

If the downloaded file has a status of AVAIL, a reset does not change its status. If another file is sent down, it overwrites that file because the ACTIVE file has not changed and the newly downloaded file always occupies the location just behind the ACTIVE file.

Example of Sending a File from the Configuration Program

For example, suppose that this is the view of the software that is displayed by the **list** command:

```
Boot Config> list

BANK A                               BANK B
IMAGE - ACTIVE                       IMAGE - AVAIL
CONFIG 1 - ACTIVE                    CONFIG 1 - AVAIL
CONFIG 2 - AVAIL                     CONFIG 2 - AVAIL
CONFIG 3 - NONE                      CONFIG 3 - AVAIL
CONFIG 4 - NONE                      CONFIG 4 - NONE
```

The Configuration Program sends a config file to BANK A, CONFIG 2. If the configuration is marked in the Configuration Program to be loaded immediately, the IBM 2216 performs a reset immediately after it received the new configuration. The Send command of the Configuration Program in this situation is composed of these two actions:

1. Send Config to CONFIG 2 as PENDING
2. Reset

After these two actions, the IBM 2216 configuration looks like this:

```
BANK A                               BANK B
IMAGE - ACTIVE                       IMAGE - AVAIL
CONFIG 1 - AVAIL                     CONFIG 1 - AVAIL
CONFIG 2 - ACTIVE                    CONFIG 2 - AVAIL
CONFIG 3 - NONE                      CONFIG 3 - AVAIL
CONFIG 4 - NONE                      CONFIG 4 - NONE
```

CONFIG 1 has become AVAIL and CONFIG 2 has become ACTIVE.

If the Configuration Program were now used to send down a new configuration to the IBM 2216 and the file were not marked to be loaded at any specified time, the view of the software in the IBM 2216 would look like this:

```
BANK A                               BANK B
IMAGE - ACTIVE                       IMAGE - AVAIL
CONFIG 1 - AVAIL                     CONFIG 1 - AVAIL
CONFIG 2 - ACTIVE                    CONFIG 2 - AVAIL
CONFIG 3 - AVAIL                     CONFIG 3 - AVAIL
CONFIG 4 - NONE                      CONFIG 4 - NONE
```

After this action, CONFIG 3 is AVAIL. The new configuration file has been loaded in this location.

Note: You should exercise caution here because any on-board configuration changes could result in overwriting the CONFIG 3 file. Because the configuration file in CONFIG 3 was sent down without any time specified for resetting the server, it is currently not in use. It can be overwritten either when another file is sent from the Configuration Program or when a file is saved using the **write** command from the command line interface. You can use the Copy command to move it to another location to protect it (see “Using the Copy Command” on page D-9).

Change Management Functions

A few change management commands are describe in this section. For complete details of change management, refer to “Performing Change Management Operations” in the Multiprotocol Access Services Software User’s Guide.

Describe Load Images

At Boot `config>`, type **describe 2216**. The Product ID, microcode version number, release number, maintenance number, PTF, Feature, and RPQ numbers and the date of the operational software image are displayed.

Describe Config Images

At Boot `config>`, type **describe config**. For each configuration file that is loaded, its bank, internal location (for example, CONFIG 1), version, and level is displayed.

Disable Dumping

The IBM 2216 can be set up to dump the contents of memory to permanent storage in the unlikely event of a complete system failure. If dumping is enabled, using this selection will cause the IBM 2216 *not* to dump to disk.

To disable dumping, type **talk 6** or **t 6** at the * prompt, press **Enter**, and then type **disable dump memory** or **dis dump** at the `Config>` prompt. You will see the message:

```
System memory dump function disabled successfully.
```

Enable Dumping

This command enables the dumping of memory without intervention from anyone in the event that the IBM 2216 has a catastrophic error. The IBM 2216 will dump memory onto the hard disk. Once a successful dump has been taken, the IBM 2216 attempts to restart. Depending upon the failure of the IBM 2216, it cannot always restart. In this case, you should restart it manually and call a service person who will dial into the IBM 2216 to determine the nature and the causes of the failure.

Before you can enable dumping, you must first enable system rebooting. To enable system rebooting, enter the following commands at the `Config>` prompt.

```
enable reboot-system
enable dump-memory
```

Finally, to enable dumping, type **t 6** at the * prompt, press **Enter**, and then type **enable** or **ena** at the `Config>` prompt. You will see the message:

```
System memory function enabled successfully
```

The default state is to have dumping enabled.

Erase Files

The IBM 2216 has a DOS file system structure with user access files in the `/sys0` and `/sys1` banks. The contents of these banks are the operational software load images and the configuration files. Note that the following rules apply to erasing files from the IBM 2216:

- Image files that are not ACTIVE can be overwritten anytime
- ACTIVE image files *cannot* be erased
- ACTIVE configuration files *cannot* be erased

To erase a file, at the `Boot config>` prompt, type **erase**. Follow the prompts. If you select a file to erase that is **BROKEN** or **NONE**, the erase option is discontinued.

Using the Copy Command

The Copy command allows you to move a file from one location in the storage area to another. This command allows you to change the status as well. The file that you move always receives the status of the storage area that it is moved to. For example, suppose that you have this scenario:

- The configuration file in **BANK A CONFIG 1** is **AVAIL**. The configuration file in **BANK B CONFIG 1** is **PENDING**.
- You copy the configuration in **BANK A CONFIG 1** to **BANK B CONFIG 1**.

In this case, the original configuration file in **BANK A CONFIG 1** remains unchanged and **AVAIL**. The configuration that was in **BANK B CONFIG 1** is overwritten by a copy of the configuration file that is in **BANK A CONFIG 1**. This copy retains the status of the file that it overwritten, in this case, **PENDING**.

These are the prompts that you would use to perform this copy process.

```
Boot config> copy config
```

```
Copy FROM Bank number? A
```

```
Copy FROM Config number? 1
```

```
Copy TO Bank number? B
```

```
Copy TO Config number? 1
```

If you copy an image, the same rules apply except that image files can be copied only from Bank to Bank. These steps describe how the copy of an image affects the image that was previously in the Bank:

1. The copy overwrites the image that was previously in the Bank.
2. The copy acquires the status of the image that was previously in the Bank.

File Transfer

Table D-1 on page D-10 defines the ways in which you can transfer configuration files and operational software files to and from the IBM 2216.

Table D-1. File Transfer

File Transfer Method	Type of Connection
<p>TFTP Get command from the IBM 2216 to the workstation that has the binary configuration file, to download operational software images and configuration files to the IBM 2216. Files sent using TFTP must be binary, or the IBM 2216 cannot use them. Use the Create command of the Configuration Program to save configuration files in binary format before downloading them to the IBM 2216.</p> <p>After the IBM 2216 is operational in the network, you can use the TFTP Put command over IP to upload a file from the IBM 2216 to a workstation. The file will be uploaded in binary format. Both operational software and configuration files can be uploaded.</p> <p>Use the Read router configuration option of the Configuration Program to make an uploaded configuration file usable by the Configuration Program so that you can change some parameter values in it.</p> <p>Note: Using TFTP Put is a way to retrieve files from the IBM 2216 if the Retrieve option of the Configuration Program is not available.</p>	<ol style="list-style-type: none"> 1. SLIP connection (using the TFTP Get command to download files to the IBM 2216). 2. IP connection of operational IBM 2216 over functioning network (using the TFTP Get and Put commands to download and upload files).
<p>Xmodem in ProComm or an equivalent communications program from the workstation. This method uses ASCII terminal emulation and can download files to the IBM 2216. The IBM 2216 does not have to be operational in the network to use this method. Configuration and operational files must be in binary format to be used by the IBM 2216.</p> <p>Note: This is a second way to retrieve files from the IBM 2216 if the Retrieve option of the Configuration Program is not available.</p>	<p>Serial connection through a modem (PCMCIA or an external modem) or through a null modem.</p>
<p>The Communications Option of the Configuration Program (actually, the protocol for this is SNMP). This method cannot be used until the IBM 2216 is operational in the network. The files are not binary, but are in a format that is internal to the Configuration Program. This function can send configuration files to the IBM 2216 and retrieve them from the server.</p> <p>Note: The Retrieve Option is available only in the version of the Configuration Program that runs in the AIX environment.</p>	<p>IP connection of operational IBM 2216 over functioning network.</p>

Appendix E. Adapter Plugging Defaults

Units assembled at the factory follow the plugging rules that are described in this appendix.

Plugging Sequences

Table E-1 illustrates how the slots are numbered: two rows of four slots, numbered 1 through 8:

Slot 1	Slot 2	Slot 3	Slot 4
Slot 5	Slot 6	Slot 7	Slot 8

The following tables show the default sequence of installation for the various adapters.

- FC 2280 and FC 2281 are installed left to right, beginning with slot 1. A maximum of six can be installed in any single IBM 2216.

first	third	fifth	
second	fourth	sixth	

- Other adapters are installed right-to-left in the first-available slot beginning with slot 8 on the bottom and far right.

eighth	sixth	fourth	third
seventh	fifth	second	first

Slots and Adapters

There are two large slots, designated *A* and *B*, on the IBM 2216. Slot *A* is unused. Slot *B* is occupied by the system card. In addition, there are eight adapter slots, designated 1 through 8.

- No more than **six** of any combination of Token-Ring (FC 2280) and Ethernet (FC 2281) adapters can be installed.
- If a combination of **six** 2280 and 2281 adapters is to be installed, no other adapters will be installed.
- If a combination of **five** 2280 and 2281 adapters is to be installed, then two additional adapters can also be installed.
- The IBM 2216 supports a maximum of:
 - **Four** ESCON adapters (FC 2287)
 - **Two** ATM adapters (FC 2284 or FC 2293)
 - **Four** ISDN adapters (FC 2283 or FC 2292)

Note: You can configure a 2216 with as many high speed adapters (FDDI FC 2286, 10/100-Mbps Ethernet FC 2288, and HSSI FC 2289) as desired; however, you may not be able to achieve full media throughput concurrently on all the adapters. When planning for installation, review system performance expectations with an IBM representative.

Any adapter can be installed in any of the eight adapter slots with the following restrictions:

- 1** If the 2-port Token-Ring (FC 2280) or 2-port Ethernet (FC 2281) adapter is plugged into slot 3 and active, then slot 4 cannot be used.
- 2** If the 2-port Token-Ring (FC 2280) or 2-port Ethernet (FC 2281) is plugged into slot 4 and active, then slot 3 cannot be used.
- 3** If the 2-port Token-Ring (FC 2280) or 2-port Ethernet (FC 2281) adapter is plugged into slot 7 and active, then slot 8 cannot be used.
- 4** If the 2-port Token-Ring (FC 2280) or 2-port Ethernet (FC 2281) adapter is plugged into slot 8 and active, then slot 7 cannot be used.

Appendix F. Common Tasks

This appendix provides a series of questions and answers dealing with common IBM 2216 installation, operation, and maintenance tasks, with suggestions as to where to find further help in performing them.

LED States / Adapter Status

Question How do I check the state of the adapters in my IBM 2216?

Answer The LED state on the front of the adapters indicate the status of the adapter. (See "Adapter Card Status" on page 1-3.)

The Firmware Interface

Question What is the firmware interface? How do I access it?

Answer The firmware is the microcode lying underneath the operational code running on the 2216. It is used primarily by service personnel in problem determination. The firmware is accessed by booting the IBM 2216 and stopping the boot process with the **F1** key. It displays a menu with a number of options. Briefly, you should have a VT220 terminal with the following settings: 19.2 Kbps, 8-N-1. You can use a null modem cable for local access or a modem attachment for remote access.

See Chapter 3, "Accessing the 2216" on page 3-1 for more information.

Command Line Interface

Question How do I access the command line interface (the operating code) from within the firmware?

Answer From within the **firmware menu system** (System Management Services), press **F9**. The * prompt is displayed after the system boots. The command line interface is described in the *Multiprotocol Access Services Software User's Guide*.

Navigating Through the Command Line Interface

Question How do I use the commands in the Command Line Interface?

Answer The structure of the interface is shown in Figure F-1 on page F-2.

The *Multiprotocol Access Services Software User's Guide* describes the entire command line interface. The basic prompts that you use are the:

- * prompt, which is the OPerating CONsole (OPCON) prompt, the initial entry point to the command line interface
- Config> prompt, which is used for configuration changes
- + prompt, which is known as monitoring or GWCON.

The basic commands are:

- Type **?** and press **Enter** at any time to view a list of possible commands.
- Type **exit** and press **Enter** to return to the + prompt and to the Config> prompt.
- Press the **Ctrl-p** keys to return to the * prompt.

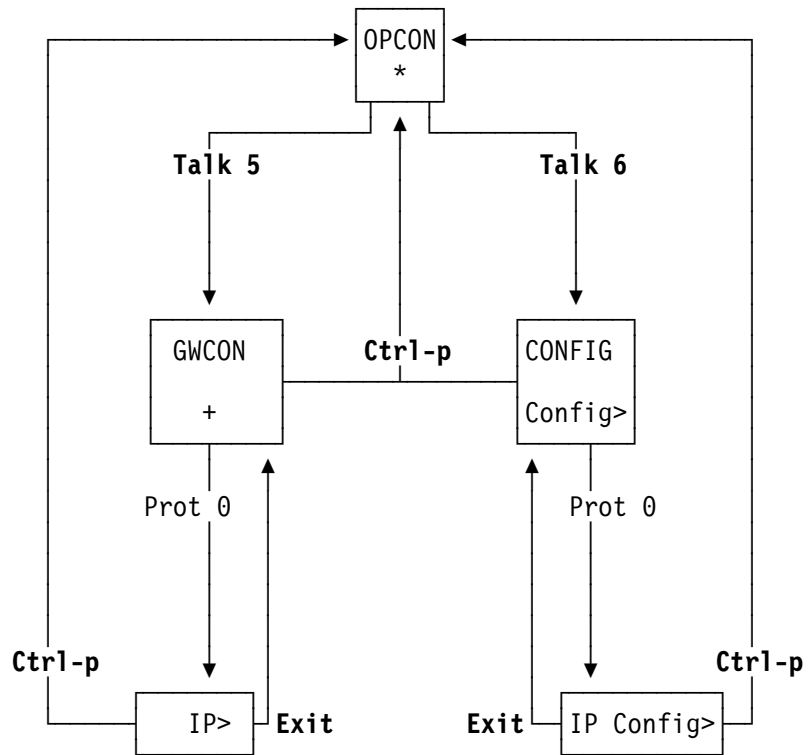

Figure F-1. Structure of the Command Line Interface (with the protocol command as an example)

Displaying List of Configured Interfaces

Question How do I display a list of active interfaces?

Answer

- 1** Access the command line interface (the * prompt).
- 2** Type **talk 6** and press **Enter** twice to reach the Config> prompt.
- 3** Enter **list dev**.
- 4** Press **Ctrl-p** to return to the OPCON (*) prompt.

Displaying the Operational State of the Interfaces

Question How do I display the state (up, down, disabled, etc.) of an interface?

Answer

- 1** Access the command line interface (the * prompt).
- 2** Type **talk 5** and press **Enter** twice to reach the + (monitoring) prompt.
- 3** Enter **configuration**.
- 4** Press **Ctrl-p** to return to the OPCON (*) prompt.

Verifying Connectivity

Question How do I verify that a given IP address is online?

Answer

- 1** Access the command line interface (the * prompt).
- 2** Type **talk 5** and press **Enter** twice to reach the + prompt.
- 3** Type **protocol** and press **Enter**.
- 4** Type **ip** and press **Enter**. The prompt changes to IP>.
- 5** Type **ping IP address value** and press **Enter**. Press **Enter** to stop the ping process.
- 6** Type **exit** at the IP> prompt and press **Enter**. The prompt changes to +.
- 7** Press **Ctrl-p** to return to the OPCON (*) prompt.

Viewing Vital Software Data

Question How do I view vital software data?

Answer

- 1** At the * prompt, type **talk 6** and press **Enter** twice. The Config> prompt appears.
- 2** Enter **boot**.
- 3** Enter **describe**. The vital software data is displayed.
- 4** Press **Ctrl-p** to return to the OPCON (*) prompt.

Viewing Vital Hardware Data

Question How do I view vital hardware data?

Answer

- 1** Access the firmware main menu: During boot-up, press **F1** at the Prematurely terminate boot sequence prompt.
- 2** Select **4. Utilities**.
- 3** Select **9. View or Set Vital Product Data**.
- 4** Select **Hardware Vital Product Data**. The vital hardware data is displayed.
- 5** Return to the firmware main menu.
- 6** Press **F9** to load the operating software.

Adding an Adapter at Initial Configuration

Question How do I add an adapter to the software configuration when the IBM 2216 is being initially configured?

Answer First, perform installation of the 2216 and install any additional adapters into the 2216.

- When the 2216 is initially installed, it does not have any software configuration.
- The operating system will put you at the `Config only>` prompt.

1 Enter **add device** *type of device*.

Note: The steps only create the interface. You still have to use the **net** command to configure characteristics unique to that interface (for example, T/R, Ethernet, PPP, FR, SDLC, X.25). You also need to use the **protocol** command to configure protocols on the interface.

For example, **add device token**
or, **add device ?** to see a list of device choices

2 Enter the device slot number (1–8).

3 If you are adding an interface on a single-port adapter, go to step 4 on page F-5. Otherwise, continue with this step.

Enter the port number (0–7, depending on the type of adapter).

The range of port numbers supported depends on the multi-port adapter type:

- For the Token-Ring (FC 2280) and Ethernet (FC 2281) adapters, port numbers 1 and 2 are supported.
- For the 8-port EIA-232E/V.24 (FC 2282) and 8-port X.21 adapters, port numbers 0–7 are supported.
- For the 6-port V.35/V.36 (FC 2290) adapter, port numbers 0–5 are supported.

- 4 Make a note of the interface number to which this port is assigned and the net number.

Repeat steps 1 to 4 if you have a multi-port adapter and you want to have more than one interface defined on that adapter.

Write the changes to save the configuration.

Reload the IBM 2216 to make the configuration changes active.

Adding an Adapter after Initial Configuration

Question How do I add an adapter after the IBM 2216 has been initially configured?

Answer First, perform hardware installation of the adapter. Then:

- 1 Access the command line interface (* prompt).
- 2 Type **talk 6** and press **Enter** twice to reach the Config> prompt.
- 3 Enter **add device** *type of device*.

For example, **add device x21**

or, **add device ?** to see a list of device choices

The following two steps do not apply when a dial-circuit device is being added.

- 4 Enter the device slot number (1–8).
- 5 If you are adding an interface on a single-port adapter, go to step 6. Otherwise, continue with this step. Enter the port number (0–7, depending on the type of adapter).

The range of port numbers supported depends on the multi-port adapter type:

- For the Token-Ring (FC 2280) and Ethernet (FC 2281) adapters, port numbers 1 and 2 are supported.
- For the 8-port EIA-232E/V.24 (FC 2282) and 8-port X.21 adapters, port numbers 0–7 are supported.
- For the 6-port V.35/V.36 (FC 2290) adapter, port numbers 0–5 are supported.

- 6 Make a note of the interface number to which this port is assigned and the net number.
- 7 Enter **net** *net number* to enable you to configure interface-unique characteristics.
- 8 Enter **exit** after configuring the interface.
- 9 Use the **protocol** command to configure protocols on the interface.
- 10 Enter **write** to save your changes.
- 11 Press **Ctrl-p** to return to the OPCON (*) prompt.
- 12 Use the **activate** command within **talk 5** to bring the new interface online to the network without rebooting the box. There are

restrictions to this capability. See the “Configuring Spare Interfaces” heading in the *Multiprotocol Access Services Software User’s Guide*.

Running Quick Configuration

Question How do I run the Quick Configuration program?

Answer First, make sure each adapter has been “added” (see “Adding an Adapter at Initial Configuration”). Then, at the Config (only) or Config> prompt, enter **qc**.

Disabling an Adapter Port

Question How do I disable a configured adapter port to remove the adapter from the software configuration?

Answer

- 1** Access the command line interface (* prompt).
- 2** Type **talk 6** and press **Enter** twice to reach the Config> prompt.
- 3** Enter **list device**.
- 4** Make a note of the interface number of the adapter you wish to disable.
- 5** Enter **disable interface** *interface number*.
- 6** Enter **write** to save your changes. The next time that the 2216 is rebooted the configuration changes become active.

For details of this procedure, refer to the *Multiprotocol Access Services Software User’s Guide*.

Enabling an Adapter Port

Question How do I enable a configured adapter port that was disabled using **disable interface** (in “Disabling an Adapter Port”)?

Use this procedure to enable the port the next time that you reboot the 2216.

Answer

- 1** Access the command line interface (* prompt).
- 2** Type **talk 6** and press **Enter** twice to reach the Config> prompt.
- 3** Enter **list device**.
- 4** Make a note of the interface number of the adapter you wish to enable.
- 5** Enter **enable interface** *interface number*.
- 6** Enter **write** to save your changes. The next time that the 2216 is rebooted the configuration changes become active.

For details of this procedure, refer to the *Multiprotocol Access Services Software User’s Guide*.

Suspend Traffic on an Adapter Port

Question How do I disable a configured adapter port to remove or test an adapter?

Answer

- 1** Access the command line interface (* prompt).
- 2** Type **talk 5** and press **Enter** twice to reach the + prompt.
- 3** Enter the **configuration** command.
- 4** Make a note of the interface number of the adapter that you want to disable.
- 5** Enter **disable interface** *interface number*.

Resume Traffic on an Adapter Port

Question How do I enable a configured adapter port (that was disabled using the **talk 5 disable** command in “Suspend Traffic on an Adapter Port”) to resume traffic?

Answer

- 1** Access the command line interface (* prompt).
- 2** Type **talk 5** and press **Enter** twice to reach the + prompt.
- 3** Enter the **configuration** command.
- 4** Make a note of the interface number of the adapter you wish to enable.
- 5** Enter **test** *interface number*.

Note: If you use the **test** command to enable an interface that has been configured at the Config> prompt (from **talk 6**) as disabled, when you reboot the 2216 the interface will be disabled again.

Therefore, you should also use the Config> **enable interface** command to ensure that the interface is enabled the next time a reboot does occur.

For details of this procedure, refer to the *Multiprotocol Access Services Software User's Guide*.

Removing and Deleting an Adapter

Question How do I remove and delete an adapter from the configuration?

Answer

- 1** Access the command line interface (* prompt).
- 2** Type **talk 6** and press **Enter** twice to reach the Config> prompt.
- 3** Enter **list device**.
- 4** Write down the interface number of the adapter that you wish to delete.

Note: If you are removing a multi-port adapter, then you need to record the interface number of all interfaces configured for that adapter.

- 5** Enter **delete interface interface number**.
- 6** At the Are you sure? prompt, enter **y**.
- 7** Enter **write** to save your changes.
- 8** Reload the IBM 2216 to make the configuration changes active.

For details of this procedure, refer to the *Multiprotocol Access Services Software User's Guide*.

Up-to-Date IBM 2216 Information

Question How can I find out the most current information about the IBM 2216?

Answer Point your web browser to
<http://www.networking.ibm.com/216/216prod.html>

Disabling Interfaces that Have WAN Reroute Enabled

Question How do I ensure that WAN Reroute does not try to automatically enable an alternate interface that is on an adapter about to be removed?

Answer

- 1** Access the command line interface (the * prompt).
- 2** Type **talk 5** and press **Enter** twice to reach the + (monitoring) prompt.
- 3** Type **disable slot slot#** or **disable interface#** for each interface on the adapter. For example:

```
+ disable slot 4
```

```
Interface 4 is enabled as a WAN Reroute alternate circuit and should be disabled as an alternate circuit if you will be removing the adapter
```

```
Do you want to disable WAN Reroute on this interface? (Yes, No): [No] Yes
```

```
Interface 4 has been disabled as a WAN Reroute alternate circuit
```

```
(adapter is removed and replaced)
```

Enabling WAN Reroute after You Have Disabled it

Question How do I enable WAN Reroute to automatically enable an alternate interface that is on an adapter that has been replaced?

Answer

- 1** Access the command line interface (the * prompt).
- 2** Type **talk 5** and press **Enter** twice to reach the + (monitoring) prompt.
- 3** Type **enable slot slot#** to start a self-test for each interface on the adapter **or** type **test interface#** for each interface that you want to bring up.

If you start a self-test for an alternate interface and the self-test is successful, the alternate interface will remain up even though it may not be needed to back-up a primary interface. If this happens, you can issue the **talk 5 disable interface#** command to put the alternate interface back into the standby (disabled) state.

The following is a sample:

```
+ enable slot 4
```

```
Interface 4 is configured as a WAN Reroute alternate circuit.  
Do you want to enable WAN Reroute on this interface? (Yes, No):[No] Yes
```

```
Interface 4 is enabled as a WAN Reroute alternate circuit.  
Are you sure that you want to test this interface? (Yes, No): [No] Yes  
Testing net 4 ATM/0...successful  
+
```

Remote File Download

Question How do I download a configuration file to the 2216 using the Firmware Menu System?

Answer Use the Systems Management Services.

- 1** Using a local console, select **4. Disable Unattended Mode** from the Systems Management Utilities menu in the firmware to put the 2216 in ATTENDED mode. (Be sure to remember the password)
- 2** To put the 2216 into the correct monitor mode for the remote console that is going to be used, reboot the 2216 and press **Y** at the DO YOU WANT TO CHANGE THE MONITOR TYPE? prompt. Select the number next to the option for the Monitor type.
- 3** Remove the local console connection and reboot the 2216 again. Do a hardware reset to put the 2216 in ATTENDED mode. (Do not use the **reload** command.)
- 4** Wait at least 90 seconds for the 2216 to reach the POWER-ON PASSWORD after rebooting before attempting to remotely connect to the 2216.

- 5** Dial in to the 2216's PCMCIA modem with a TTY console. The console settings must be:
 - Speed = 19200 bps
 - Data bits = 8
 - Parity = No
 - Stop bits = 1
- 6** Once the connection is established, type in the password and press **Enter**. The password will not be displayed, but you should get an * on your screen for every character that you enter.
- 7** Press **F1** to terminate the boot sequence and enter the firmware Systems Management Services menu.
- 8** Select **4. Utilities** from the Systems Management Services menu.
- 9** Select **12. Change Management** from the Systems Management Utilities menu.
- 10** For MODEM: Configuration file must be on remote console, but no IP addresses are needed.
 - a. Select **12. Xmodem software** from the Change Management Software Control menu.
 - b. Select **1. Config** from the Select Type dialog box.
 - c. Select the Bank to send the configuration file to from the Select Bank dialog box.
 - d. Select the config # to send the configuration file to from the Select Config dialog box.
 - e. When the BEGIN FILE TRANSFER dialog box closes, use your Xmodem software to transfer the files. For example, with PROCOMM:
 - Press the PAGE UP key when the dialog box disappears.
 - Press X for xmodem mode.
 - Type in the path and file name of the configuration you are going to transfer to the 2216.
 - Press ENTER.
- 11** For TFTP: You must have a PCMCIA networking card in the PCMCIA slot before booting the 2216 and be connected to a network that has the configuration file you are going to transfer to the 2216.

Note: IP addresses need to be set up on the PCMCIA slot using the System Management Utilities menu and select **11. Remote Initial Program Load Setup** before a TFTP can be done.

 - a. Select **10. TFTP software** from the Change Management Software Control menu.
 - b. Select **1. Config** from the Select Type dialog box.
 - c. Select the Bank to send the configuration file to from the Select Bank dialog box.

- d. Select the config # to send the configuration file to from the Select Config dialog box.
- e. Type in the path and name of the Configuration file to be downloaded onto the 2216 and press **Enter**.

Spare Interfaces

Question Can I move traffic from a defective adapter to another adapter without restarting the 2216?

Answer Yes. Use the spare interface function of the 2216. See "Configuring Spare Interfaces" in the *Multiprotocol Access Services Software User's Guide*.

Appendix G. Notices

References in this publication to IBM products, programs, or services do not imply that IBM intends to make these available in all countries in which IBM operates. Any reference to an IBM product, program, or service is not intended to state or imply that only IBM's product, program, or service may be used. Subject to IBM's valid intellectual property, or other legally protectable rights, any functionally equivalent product, program, or service that does not infringe any of IBM's intellectual property rights may be used instead of the IBM product, program, or service. The evaluation and verification of operation in conjunction with other products, except those expressly designated by IBM, are the user's responsibility.

IBM may have patents or pending patent applications covering subject matter in this document. The furnishing of this document does not give you any license to these patents. You can send license inquiries, in writing, to:

IBM Director of Licensing
IBM Corporation
500 Columbus Avenue
Thornwood, NY 10594 USA

Electronic Emission Notices

Federal Communications Commission (FCC) Statement

Note: This equipment has been tested and found to comply with the limits for a Class A digital device, pursuant to Part 15 of the FCC Rules. These limits are designed to provide reasonable protection against harmful interference when the equipment is operated in a commercial environment. This equipment generates, uses, and can radiate radio frequency energy and, if not installed and used in accordance with the instruction manual, may cause harmful interference to radio communications. Operation of this equipment in a residential area is likely to cause harmful interference, in which case the user will be required to correct the interference at his own expense.

Properly shielded and grounded cables and connectors must be used in order to meet FCC emission limits. IBM is not responsible for any radio or television interference caused by using other than recommended cables and connectors or by unauthorized changes or modifications to this equipment. Unauthorized changes or modifications could void the user's authority to operate the equipment.

This device complies with Part 15 of the FCC Rules. Operation is subject to the following two conditions: (1) this device may not cause harmful interference, and (2) this device must accept any interference received, including interference that may cause undesired operation.

Industry Canada Class A Emission Compliance Statement

This Class A digital apparatus meets the requirements of the Canadian Interference-Causing Equipment Regulations.

Avis de conformité aux normes d'Industrie Canada

Cet appareil numérique de la classe A respecte toutes les exigences du Règlement sur le matériel brouilleur du Canada.

Japanese Voluntary Control Council for Interference (VCCI) Statement

This is a Class A product based on the standard of the Voluntary Control Council for Interference by Information Technology Equipment (VCCI). If this equipment is used in a domestic environment, radio disturbance may arise. When such trouble occurs, the user may be required to take corrective actions.

この装置は、情報処理装置等電波障害自主規制協議会（VCCI）の基準に基づくクラスA情報技術装置です。この装置を家庭環境で使用すると電波妨害を引き起こすことがあります。この場合には使用者が適切な対策を講ずるよう要求されることがあります。

CISPR22 Compliance Statement

This product has been tested and found to comply with the limits for Class A Information Technology Equipment according to CISPR 22/European Standard EN 55022. The limits for Class A equipment were derived for commercial and industrial environments to provide reasonable protection against interference with licensed communication equipment. **Warning:** This is a Class A product. In a domestic environment this product may cause radio interference in which case the user may be required to take adequate measures.

Taiwanese Class A Warning Statement

警告使用者：
這是甲類的資訊產品，在
居住的環境中使用時，可
能會造成射頻干擾，在這種
情況下，使用者會被要求
採取某些適當的對策。

European Union (EU) Mark of Conformity Statement

This product is in conformity with the protection requirements of EC Council Directive 89/336/EEC on the approximation of the laws of the Member States relating to electromagnetic compatibility. IBM cannot accept responsibility for any failure to satisfy the protection requirements resulting from a non-recommended modification of the product, including the fitting of non-IBM option cards.

The product bears the Telecom CE mark (CE 168 X) for ISDN Basic Rate complying with I-CTR3 (Bridging measures) as per the European directive 91/263/EEC (TTE directive). The product bears the Telecom CE mark (CE 168 X) for: V.24/V.28,V36 and X.21 electrical interfaces complying with NET 1 and with NET 2 physical level. ISDN Basic Rate complying with I-CTR3 (Bridging measures) as per the European directive 91/263/EEC (TTE directive).

Warning: This is a Class A product. In a domestic environment this product may cause radio interference in which case the user may be required to take adequate measures.

Zulassungsbescheinigung laut dem Deutschen Gesetz über die elektromagnetische Verträglichkeit von Geräten (EMVG) vom 30. August 1995 (bzw. der EMC EG Richtlinie 89/336)

Dieses Gerät ist berechtigt in Übereinstimmung mit dem Deutschen EMVG das EG-Konformitätszeichen - CE - zu führen.

Verantwortlich für die Konformitätserklärung nach Paragraph 5 des EMVG ist die IBM Deutschland Informationssysteme GmbH, 70548 Stuttgart.

Informationen in Hinsicht EMVG Paragraph 3 Abs. (2) 2:

Das Gerät erfüllt die Schutzanforderungen nach EN 50082-1 und EN 55022 Klasse A.

EN 55022 Klasse A Geräte müssen mit folgendem Warnhinweis versehen werden:
"Warnung: dies ist eine Einrichtung der Klasse A. Diese Einrichtung kann im Wohnbereich Funkstörungen verursachen; in diesem Fall kann vom Betreiber verlangt werden, angemessene Maßnahmen durchzuführen und dafür aufzukommen."

EN 50082-1 Hinweis:

"Wird dieses Gerät in einer industriellen Umgebung betrieben (wie in EN 50082-2 festgelegt), dann kann es dabei eventuell gestört werden. In solch einem Fall ist der Abstand bzw. die Abschirmung zu der industriellen Störquelle zu vergrößern."

Anmerkung:

Um die Einhaltung des EMVG sicherzustellen sind die Geräte, wie in den IBM Handbüchern angegeben, zu installieren und zu betreiben.

Telecommunication Notices

FCC Part 68 Compliance Information:

Features and optional adapters for the IBM 2216 comply with Part 68 of the FCC rules. The label included on the adapter tray contains, among other information, the FCC registration number and Ringer Equivalence Number (REN), if applicable for this equipment. If requested, provide this information to your telephone company.

The features and adapters included are:

Feature Code	Part Name
2283	1-Port ISDN PRI (T1/J1) Adapter LIC 283 with interface code 04DU9-1SN, service code 6.0N and jack type RJ48C.

The REN is useful to determine the quantity of devices you may connect to your telephone line and still have those devices ring when your number is called. In most, but not all areas, the sum of the RENs of all devices should not exceed five (5.0). To be certain of the number of devices you may connect to your line, as determined by the REN, you should call your local telephone company to determine the maximum REN for your calling area.

If the IBM 2216 causes harm to the telephone network, the Telephone Company may discontinue your service temporarily. If possible, they will notify you in advance. But if advance notice isn't practical, you will be notified as soon as possible. You will be advised of your right to file a complaint with the FCC.

Your telephone company may make changes in its facilities, equipment, operations, or procedures that could affect the proper operation of your equipment. If they do, you will be given advance notice so as to give you an opportunity to maintain uninterrupted service.

If trouble is experienced with this equipment, for repair or warranty information, in the United States, call IBM at **1-800-IBM-SERV**. In Canada, call IBM at **1-800-465-6600**.

No repairs can be performed by the customer.

Industry Canada Information:

NOTICE: The Industry Canada label identifies certified equipment. This certification means that the equipment meets certain telecommunications network protective, operational and safety requirements. Industry Canada does not guarantee the equipment will operate to the user's satisfaction.

Before installing this equipment, users should ensure that it is permissible to be connected to the facilities of the local telecommunications company. The equipment must also be installed using an acceptable method of connection. In some cases, the company's inside wiring associated with a single line individual service may be extended by means of a certified connector assembly (telephone extension cord). The customer should be aware that compliance with the above conditions may not prevent degradation of service in some situations.

Repairs to certified equipment should be made by an authorized Canadian maintenance facility designated by the supplier. Any repairs or alterations made by the user to this equipment, or equipment malfunctions, may give the telecommunications company cause to request the user to disconnect the equipment.

Users should ensure for their own protection that the electrical ground connections of the power utility, telephone lines and internal metallic water pipe system, if present, are connected together. This precaution may be particularly important in rural areas.

CAUTION: Users should not attempt to make such connections themselves, but should contact the appropriate electrical inspection authority, or electrician, as appropriate.

AVIS : L'étiquette d'Industrie Canada permet d'identifier un équipement homologué. Cette homologation signifie que cet équipement satisfait certaines exigences en matière de protection, d'exploitation et de sécurité du réseau de télécommunications. Industrie Canada n'offre aucune garantie que le fonctionnement de cet équipement soit à la satisfaction de l'utilisateur.

Avant d'installer cet équipement, l'utilisateur doit s'assurer qu'il a la permission de le raccorder aux installations de l'entreprise de télécommunications. L'installation de cet équipement doit aussi se faire selon un mode de raccordement acceptable. Dans certains cas, le câblage interne de l'entreprise associé au service individuel offert par une ligne d'abonné peut être prolongé au moyen d'un connecteur homologué (prolongateur de téléphone). Le client devrait être informé que la conformité de son équipement aux conditions susmentionnées n'est pas une prévention contre la dégradation du service dans certaines situations.

Toute réparation d'un équipement homologué devrait être effectuée par un service de maintenance canadien autorisé qui a été désigné par le fournisseur. Toute réparation ou modification d'équipement faite par l'utilisateur, ou tout mauvais fonctionnement, pourrait entraîner la déconnexion de cet équipement par l'utilisateur à la demande de l'entreprise de télécommunications.

Pour sa protection personnelle, l'utilisateur devrait s'assurer que les mises à la terre des services publics électriques, des lignes téléphoniques et du système interne des canalisations d'eau à tuyaux métalliques, advenant leur présence, sont interconnectées. Dans les zones rurales, il s'agit-là d'une précaution particulièrement importante à prendre.

ATTENTION : Toute tentative de connexion par l'utilisateur est à déconseiller. Il est préférable de communiquer avec le responsable de l'inspection en électricité ou un électricien, selon le cas.

United Kingdom Compliance Statement

STATEMENT OF COMPLIANCE

The United Kingdom Telecommunications Act 1984. This equipment is approved under General Approval Number NS/G/1234/J/100003

for indirect connections to the public telecommunications systems in the United Kingdom.

Trademarks

The following terms used in this publication, are trademarks or service marks of IBM Corporation in the United States or other countries:

AT	Nways	Presentation Manager
AIXwindows	Operating System/2	PS/2
ESCON	OS/2	RETAIN
IBM	Personal System/2	RS/6000
NetView	PR/SM	:
	c.XGA	

Other company, product, and service names may be trademarks or service marks of others.

Appendix H. Safety Information

 **Danger:** Before you begin to install this product, read the safety information in *Caution: Safety Information—Read This First*, SD21-0030. This booklet describes safe procedures for cabling and plugging in electrical equipment.

 **Gevaar:** Voordat u begint met de installatie van dit produkt, moet u eerst de veiligheidsinstructies lezen in de brochure *PAS OP! Veiligheidsinstructies—Lees dit eerst*, SD21-0030. Hierin wordt beschreven hoe u elektrische apparatuur op een veilige manier moet bekabelen en aansluiten.

 **Danger:** Avant de procéder à l'installation de ce produit, lisez d'abord les consignes de sécurité dans la brochure *ATTENTION: Consignes de sécurité—A lire au préalable*, SD21-0030. Cette brochure décrit les procédures pour câbler et connecter les appareils électriques en toute sécurité.

 **Perigo:** Antes de começar a instalar este produto, leia as informações de segurança contidas em *Cuidado: Informações Sobre Segurança—Leia Isto Primeiro*, SD21-0030. Esse folheto descreve procedimentos de segurança para a instalação de cabos e conexões em equipamentos elétricos.



危險：安裝本產品之前，請先閱讀
"Caution: Safety Information--Read
This First" SD21-0030 手冊中所提
供的安全注意事項。這本手冊將會說明
使用電器設備的纜線及電源的安全程序。



Opasnost: Prije nego što počnete sa instalacijom produkta, pročitatje naputak o pravilima o sigurnom rukovanju u Upozorenje: Pravila o sigurnom rukovanju - Prvo pročitaj ovo, SD21-0030. Ovaj priručnik opisuje sigurnosne postupke za priključivanje kabela i priključivanje na električno napajanje.





Upozornění: než zahájíte instalaci tohoto produktu, přečtěte si nejprve bezpečnostní informace v pokynech „Bezpečnostní informace“ č. 21-0030. Tato brožurka popisuje bezpečnostní opatření pro kabeláž a zapojení elektrického zařízení.

 **Fare!** Før du installerer dette produkt, skal du læse sikkerhedsforskrifterne i *NB: Sikkerhedsforskrifter—Læs dette først* SD21-0030. Vejledningen beskriver den fremgangsmåde, du skal bruge ved tilslutning af kabler og udstyr.

 **Gevaar** Voordat u begint met het installeren van dit produkt, dient u eerst de veiligheidsrichtlijnen te lezen die zijn vermeld in de publikatie *Caution: Safety Information - Read This First*, SD21-0030. In dit boekje vindt u veilige procedures voor het aansluiten van elektrische apparatuur.

 **VAARA:** Ennen kuin aloitat tämän tuotteen asennuksen, lue julkaisussa *Varoitus: Turvaohjeet—Lue tämä ensin*, SD21-0030, olevat turvaohjeet. Tässä kirjassessa on ohjeet siitä, miten sähkölaitteet kaapeloidaan ja kytketään turvallisesti.

 **Danger :** Avant d'installer le présent produit, consultez le livret *Attention : Informations pour la sécurité — Lisez-moi d'abord*, SD21-0030, qui décrit les procédures à respecter pour effectuer les opérations de câblage et brancher les équipements électriques en toute sécurité.

 **Vorsicht:** Bevor mit der Installation des Produktes begonnen wird, die Sicherheitshinweise in *Achtung: Sicherheitsinformationen—Bitte zuerst lesen*, &ibm. Form SD21-0030. Diese Veröffentlichung beschreibt die Sicherheitsvorkehrungen für das Verkabeln und Anschließen elektrischer Geräte.

 **Vigyázat:** Mielőtt megkezdi a berendezés üzembe helyezését, olvassa el a *Caution: Safety Information— Read This First*, SD21-0030 könyvecskében leírt biztonsági információkat. Ez a könyv leírja, milyen biztonsági intézkedéseket kell megtenni az elektromos berendezés huzalozásakor illetve csatlakoztatásakor.

 **Pericolo:** prima di iniziare l'installazione di questo prodotto, leggere le informazioni relative alla sicurezza riportate nell'opuscolo *Attenzione: Informazioni di sicurezza — Prime informazioni da leggere* in cui sono descritte le procedure per il cablaggio ed il collegamento di apparecchiature elettriche.



危険： 導入作業を開始する前に、安全に関する小冊子SD21-0030 の「最初にお読みください」(Read This First)の項をお読みください。
この小冊子は、電気機器の安全な配線と接続の手順について説明しています。



위험: 이 제품을 설치하기 전에 반드시
"주의: 안전 정보-시작하기 전에"
(SD21-0030) 에 있는 안전 정보를
읽으십시오.



Fare: Før du begynner å installere dette produktet, må du lese sikkerhetsinformasjonen i *Advarsel: Sikkerhetsinformasjon — Les dette først*, SD21-0030 som beskriver sikkerhetsrutinene for kabling og tilkobling av elektrisk utstyr.



Uwaga:
Przed rozpoczęciem instalacji produktu należy zapoznać się z instrukcją:
"Caution: Safety Information - Read This First", SD21-0030.
Zawiera ona warunki bezpieczeństwa przy podłączeniu do sieci elektrycznej i eksploatacji.



Perigo: Antes de iniciar a instalação deste produto, leia as informações de segurança *Cuidado: Informações de Segurança — Leia Primeiro*, SD21-0030. Este documento descreve como efectuar, de um modo seguro, as ligações eléctricas dos equipamentos.



ОСТОРОЖНО: Прежде чем устанавливать этот продукт, прочтите Инструкцию по технике безопасности в документе "Внимание: Инструкция по технике безопасности -- Прочсть в первую очередь", SD21-0030. В этой брошюре описаны безопасные способы каблирования и подключения электрического оборудования.



Nebezpečnostvo: Pred inštaláciou výrobku si prečítajte bezpečnostné predpisy v
Výstraha: Bezpečnostné predpisy - Prečítaj ako prvé,
SD21-0030. V tejto brožúrke sú opísané bezpečnostné postupy pre pripojenie elektrických zariadení.



Pozor: Preden začnete z instalacijo tega produkta preberite poglavje: "Opozorilo: Informacije o varnem rokovanju-preberi pred uporabo," SD21-0030. To poglavje opisuje pravilne postopke za kabliranje,



Peligro: Antes de empezar a instalar este producto, lea la información de seguridad en *Atención: Información de Seguridad — Lea Esto Primero*, SD21-0030. Este documento describe los procedimientos de seguridad para cablear y enchufar equipos eléctricos.



Varning — livsfara: Innan du börjar installera den här produkten bör du läsa säkerhetsinformationen i dokumentet *Varning: Säkerhetsföreskrifter— Läs detta först*, SD21-0030. Där beskrivs hur du på ett säkert sätt ansluter elektrisk utrustning.



危險：

開始安裝此產品之前，請先閱讀安全資訊。

注意：

請先閱讀 - 安全資訊 SD21-0030

此冊子說明插接電器設備之電纜線的安全程序。

Caution Notices

CAUTION

A fully populated IBM 2216 weighs about 43.1 kg (95 lb).

LET OP:

Als alle voorzieningen geïnstalleerd zijn, weegt de IBM 2216 ongeveer 43,1 kg.

CUIDADO:

Um dispositivo IBM 2216 totalmente populado pesa cerca de 43,1 kg (95 lb).

Pas på!

En fuldt udbygget IBM 2216 vejer ca. 43,1 kg.

ATTENTION

Un IBM 2216 entièrement équipé pèse environ 43,1 kg.

ACHTUNG

Eine voll bestückte IBM 2216 wiegt ungefähr 43.1 kg.

ATTENZIONE:

Un IBM 2216 cui sono collegate tutte le unità pesa circa 43,1 kg.

CUIDADO:

Um IBM 2216 totalmente preenchido pesa cerca de 43 kg.

Precaució

Un IBM 2216 completamente equipado pesa alrededor de 43.1 kg (95 lb).

VARNING:

En fullt utbyggd IBM 2216 väger ca 43 kg.

ADVARSEL

En IBM 2216 som er fullt utstyrt, veier ca. 43 kg.

危険:

IBM 2216は装備により約43kgの重さがあります。

POZOR:

Plně osazená IBM 2216 váží zhruba 43,1 kg.

危険!

欲防止電信網路上的電壓造成損壞，除非法律明文禁止，否則在從地面切斷通信單元前，請先切斷所有的電信網路線路。

注意:

一台配置完整的 IBM 2216 重约 43.1 kg (95 lb)。

VIGYÁZAT!

A teljesen kiépített IBM 2216 berendezés tömege kb. 43,1 kg (95 lb)

При полной комплектации IBM 2216 весит около 45 кг.

VÝSTRAHA

Zariadenie IBM 2216 v plnej výbave váži cca 43.1 kg (95 lb).

UWAGA:

Całkowicie wypełnione urządzenie IBM 2216 waży około 43,1 kg.

Glossary

This glossary includes terms and definitions from:

- The *IBM Dictionary of Computing* (New York; McGraw-Hill, Inc., 1994).
- The *American National Standard Dictionary for Information Systems*, ANSI X3.172-1990, copyright 1990 by the American National Standards Institute (ANSI). Copies may be purchased from the American National Standards Institute, 11 West 42nd Street, New York, New York 10036. Definitions are identified by the symbol (A) after the definition.
- The *Information Technology Vocabulary*, developed by Subcommittee 1, Joint Technical Committee 1, of the International Organization for Standardization and the International Electrotechnical Commission (ISO/IEC JTC1/SC1). Definitions of published parts of this vocabulary are identified by the symbol (I) after the definition; definitions taken from draft international standards, committee drafts, and working papers being developed by ISO/IEC JTC1/SC1 are identified by the symbol (T) after the definition, indicating that final agreement has not yet been reached among the participating National Bodies of SC1.
- The Network Working Group Request for Comments: 1208.

The following cross-references are used in this glossary:

Contrast with: This refers to a term that has an opposed or substantively different meaning.

Synonym for: This indicates that the term has the same meaning as a preferred term, which is defined in its proper place in the glossary.

Synonymous with: This is a backward reference from a defined term to all other terms that have the same meaning.

See: This refers the reader to multiple-word terms that have the same last word.

See also: This refers the reader to terms that have a related, but not synonymous, meaning.

A

A. Ampere.

ac. Alternating current.

active. (1) Operational. (2) Pertaining to a node or device that is connected or is available for connection to another node or device.

Advanced Peer-to-Peer Networking (APPN) network node. A node that offers a broad range of end-user services and that can provide the following:

- Distributed directory services, including registration of its domain resources to a central directory server
- Topology database exchanges with other APPN network nodes, enabling network nodes throughout the network to select optimal routes for LU-LU sessions based on requested classes of service
- Session services for its local LUs and client end nodes
- Intermediate routing services within an APPN network

agent. A system that assumes an agent role.

analog. (1) Pertaining to data consisting of continuously variable physical quantities. (A)
(2) Contrast with *digital*.

ANSI. American National Standards Institute.

AppleTalk. A network protocol developed by Apple Computer, Inc. This protocol is used to interconnect network devices, which can be a mixture of Apple and non-Apple products.

APPN node. Advanced Peer-to-Peer Networking (APPN) node.

asynchronous transfer mode (ATM). A connection-oriented access service to transfer data, voice, and video on broadband networks at very high speeds. These traffic types are mixed together over the available link bandwidth rather than being isolated into dedicated chunks of bandwidth.

The current ATM is for speeds of 155 Mbps and 622 Mbps but it will be capable of speeds in range of gigabits per second.

ATM divides all traffic into fixed-length cells, each containing 48 bytes of user data and five bytes of overhead, and manages the flow of these cells through the network.

ATM. Asynchronous Transfer Mode.

attachment unit interface (AUI). In a local area network, the interface between the medium attachment unit and the data terminal equipment within a data station. (I) (A)

AUI. Attachment unit interface.

autonomous system (AS). A group of networks and routers that use the same interior gateway protocol and for which one administrative authority has responsibility.

B

Bc. Committed burst size.

Be. Excess burst size.

bps. Bits per second.

bridge. A functional unit that interconnects multiple LANs (locally or remotely) that use the same logical link control protocol but that can use different medium access control protocols. A bridge forwards a frame to another bridge based on the medium access control (MAC) address.

bridging. In LANs, the forwarding of a frame from one LAN segment to another. The destination is specified by the medium access control (MAC) sublayer address encoded in the destination address field of the frame header.

broadband. A large frequency band allowing different kinds of transmissions, such as coded voice, video, and data, at the same time.

BSC. Binary synchronous communication.

C

CAS. Channel associated signaling.

CCITT. International Telegraph and Telephone Consultative Committee. This was an organization of the International Telecommunication Union (ITU). On 1 March 1993 the ITU was reorganized, and responsibilities for standardization were placed in a subordinate organization named the Telecommunication Standardization Sector of the International Telecommunication Union (ITU-TS). "CCITT" continues to be used for recommendations that were approved before the reorganization.

CCS. (1) common channel signaling (2) change control server.

CDB. Configuration database.

CES. Circuit emulation service.

channelization. The process of breaking the bandwidth on a communication line into a number of channels, possibly of different size. Also called *time division multiplexing* (TDM).

CIR. Committed information rate.

circuit. (1) One or more conductors through which an electric current can flow. See *physical circuit* and *virtual circuit*. (2) A logic device.

circuit switching. (1) A process that, on demand, connects two or more data terminal equipment (DTEs) and permits the exclusive use of a data circuit between them until the connection is released. (I) (A) (2) Synonymous with *line switching*.

CMIP. Common Management Information Protocol.

CMIS. Common Management Information Services.

CMOT. CMIP over TCP/IP.

CNM. Communication network management.

configuration. (1) The manner in which the hardware and software of an information processing system are organized and interconnected. (T) (2) The devices and programs that make up a system, subsystem, or network.

connection. In data communication, an association established between functional units for conveying information. (I) (A)

CP. Control point.

CRC. Cyclic redundancy check.

CU logical address. The control unit (CU) address defined in the host for the 2216. This value is defined in the host Input/Output Configuration Program (IOCP) by the CUADD statement on the CNTLUNIT macro instruction. The control unit address must be unique for each logical partition defined on the same host.

D

DAS. Dual attaching system (for FDDI).

data circuit. (1) A pair of associated transmit and receive channels that provide a means of two-way data communication. (I) (2) See also *physical circuit* and *virtual circuit*.

Notes:

1. Between data switching exchanges, the data circuit may include data circuit-terminating equipment (DCE), depending on the type of interface used at the data switching exchange.
2. Between a data station and a data switching exchange or data concentrator, the data circuit includes the data circuit-terminating equipment at the data station end, and may include equipment similar to a DCE at the data switching exchange or data concentrator location.

data circuit-terminating equipment (DCE). In a data station, the equipment that provides the signal conversion and coding between the data terminal equipment (DTE) and the line. (I)

Notes:

1. The DCE may be separate equipment or an integral part of the DTE or of the intermediate equipment.
2. A DCE may perform other functions that are usually performed at the network end of the line.

data link control (DLC). A set of rules used by nodes on a data link (such as an SDLC link or a token ring) to accomplish an orderly exchange of information.

data link switching (DLSw). A method of transporting network protocols that use IEEE 802.2 logical link control (LLC) type 2. SNA and NetBIOS are examples of protocols that use LLC type 2. See also *encapsulation* and *spoofing*.

data terminal equipment (DTE). That part of a data station that serves as a data source, data sink, or both. (I) (A)

data terminal ready (DTR). A signal to the modem used with the EIA 232 protocol.

dc. Direct current.

DCD. DC distribution (module).

DCE. Data circuit-terminating equipment.

DCE. Data circuit-terminating equipment.

DC48. DC power input type -48V.

dependent LU requester (DLUR). An APPN end node or an APPN network node that owns dependent LUs, but requests that a dependent LU server provide the SSCP services for those dependent LUs.

device. A mechanical, electrical, or electronic contrivance with a specific purpose.

device address. The unit address transmitted on the channel path to select a 2216 device. It is also referred to as subchannel number in S/370 I/O architecture. This value is defined in the host IOCP by the UNITADD statement on the CNTLUNIT macro instruction for the real device.

digital. (1) Pertaining to data that consist of digits. (T)
(2) Pertaining to data in the form of digits. (A)
(3) Contrast with *analog*.

DLCI. Data link connection identifier.

DLS. Data link switching.

DLUR. Dependent LU requester.

DTE. Data terminal equipment. (A)

DTE. Data terminal equipment.

DTMF. Dual-tone modulation frequency.

DTR. Data terminal ready.

E

E&M. Earth & mark.

EIA. Electronic Industries Association.

EIA unit. A unit of measure, established by the Electronic Industries Association, equal to 44.45 millimeters (1.75 inches).

EIA 232. In data communications, a specification of the Electronic Industries Association (EIA) that defines the interface between data terminal equipment (DTE) and data circuit-terminating equipment (DCE), using serial binary data interchange.

Electronic Industries Association (EIA). An organization of electronics manufacturers that advances the technological growth of the industry, represents the views of its members, and develops industry standards.

EMIF. ESCON Multiple Image Facility.

encapsulation. In communications, a technique used by layered protocols by which a layer adds control information to the protocol data unit (PDU) from the layer it supports. In this respect, the layer encapsulates the data from the supported layer. In the Internet suite of protocols, for example, a packet would contain control information from the physical layer, followed by control information from the network layer, followed by the application protocol data. See also *data link switching (DLSw)*.

ESCD. ESCON Director.

ESCON. Enterprise Systems Connection.

ESF. Extended status flags.

Ethernet. A 10-Mbps baseband local area network that allows multiple stations to access the transmission medium at will without prior coordination, avoids contention by using carrier sense and deference, and resolves contention by using collision detection and transmission. Ethernet uses carrier sense multiple access with collision detection (CSMA/CD).

F

FANB. Fan box.

FAT. File allocation table.

fax. Hardcopy received from a facsimile machine. Synonymous with *teletcopy*.

FDDI. Fiber distributed data interface (100 Mbps fiber optic LAN)

FEP. Front-end processor.

flash memory. A data storage device that is programmable, erasable, and does not require continuous power. The chief benefit of flash memory over other programmable and erasable data storage devices is that it can be reprogrammed without being removed from the circuit board.

FR. Frame relay.

FRAD. Frame relay assembler/disassembler.

frame relay. (1) An interface standard describing the boundary between a user's equipment and a fast-packet network. In frame-relay systems, flawed frames are discarded; recovery comes end-to-end rather than hop-by-hop. (2) A technique derived from the integrated services digital network (ISDN) D channel standard. It assumes that connections are reliable and dispenses with the overhead of error detection and control within the network.

frequency. The rate of signal oscillation, expressed in hertz.

FRFH. Frame relay frame handler.

front-end processor (FEP). A processor, such as the IBM 3745 or 3174, that relieves a main frame from the communication control tasks.

FRTE. Frame relay terminal equipment.

FRU. Field replaceable unit.

FTP. File Transfer Protocol.

G

gateway. (1) A functional unit that interconnects two computer networks with different network architectures. A gateway connects networks or systems of different architectures. A bridge interconnects networks or systems with the same or similar architectures. (T) (2) In the IBM Token-Ring Network, a device and its

associated software that connect a local area network to another local area network or a host that uses different logical link protocols.

Gbps. Gigabits per second (1 000 000 000 bits per second).

GUI. Graphical user interface.

H

HDLC. High-level data link control.

high-level data link control (HDLC). An access service used over data networks. It uses a non-real-time connection.

HDLC-like data link control, for example:

- Synchronous data link control (SDLC) used with SNA, or
- Link access procedure for D-channel (LAP-D) used with ISDN.

high-performance file system (HPFS). In the OS/2 operating system, an installable file system that uses high-speed buffer storage, known as a cache, to provide fast access to large disk volumes. The file system also supports the coexistence of multiple, active file systems on a single personal computer, with the capability of multiple and different storage devices. File names used with the HPFS can have as many as 254 characters.

high-performance routing (HPR). An addition to the Advanced Peer-to-Peer Networking (APPN) architecture that enhances data routing performance and reliability, especially when using high-speed links.

hot pluggable. Refers to a hardware component that can be installed or removed without disturbing the operation of any other resource that is not connected to, or dependant on, this component.

HPDT. High-Performance Data Transfer.

HPFS. High-performance file system.

HS. High-speed.

HSA. High-speed adapter (module).

HSDS. High-Speed Digital Services.

HSSI. High-speed serial interface.

hub (intelligent). A wiring concentrator, such as the IBM 8260, that provides bridging and routing functions for LANs with different cables and protocols.

I

IDNX. Integrated Digital Network Exchange.

IEEE. Institute of Electrical and Electronics Engineers.

impedance. The combined effect of resistance, inductance, and capacitance on a signal at a given frequency.

integrated services digital network (ISDN). A digital end-to-end telecommunication network that supports multiple services including, but not limited to, voice and data.

Note: ISDNs are used in public and private network architectures.

interface. (1) A shared boundary between two functional units, defined by functional characteristics, signal characteristics, or other characteristics, as appropriate. The concept includes the specification of the connection of two devices having different functions. (T) (2) Hardware, software, or both, that links systems, programs, or devices.

Intermediate Session Routing (ISR). A type of routing function within an APPN network node that provides session-level flow control and outage reporting for all sessions that pass through the node but whose end points are elsewhere.

International Organization for Standardization (ISO). An organization of national standards bodies from various countries established to promote development of standards to facilitate international exchange of goods and services, and develop cooperation in intellectual, scientific, technological, and economic activity.

internet. A collection of networks interconnected by a set of routers that allow them to function as a single, large network. See also *Internet*.

Internet. A worldwide network connecting users through autonomous networks in industry, education, government, and research. The Internet network uses Internet Protocol (IP). The major Internet services include electronic mail, FTP, telnet, World Wide Web, and electronic bulletin boards (Usenet). For network interconnection and routing, and Transmission Control Protocol (TCP) for end-to-end control. (A)

Internet Protocol (IP). A connectionless protocol that routes data through a network or interconnected networks. IP acts as an intermediary between the higher protocol layers and the physical network. However, this protocol does not provide error recovery and flow control and does not guarantee the reliability of the physical network.

Internetwork Packet Exchange (IPX). The network protocol used to connect Novell's servers, or any workstation or router that implements IPX, with other workstations. Although similar to the Internet Protocol (IP), IPX uses different packet formats and terminology.

IP. Internet Protocol.

IPX. Internetwork Packet Exchange.

ISDN. Integrated services digital network.

ISM. IBM Solution Manager.

ISMD. IBM Software Manufacturing and Delivery.

ISO. International Organization for Standardization.

ISR. Intermediate session routing.

ITU-T. International Telecommunication Union - Telecommunication (replaces CCITT).

K

Kbps. Kilobits per second (1000 bits per second).

kVA. kilovolt amperes.

L

LAN. Local area network.

LAPD. Link access procedure for D-channel.

LCS. Logical channel station.

LED. Light-emitting diode.

LIC. Line interface coupler.

line switching. Synonym for *circuit switching*.

link. The combination of the link connection (the transmission medium) and two link stations, one at each end of the link connection. A link connection can be shared among multiple links in a multipoint or token-ring configuration.

Link Address. For a 2216 with an ESCON Channel Adapter, a port number determined as follows: If one ESCD is in the communication path, it is the ESCON Director (ESCD) port number that is attached to the host. If two ESCDs are in the path, it is the host-side port number of the ESCD defined with the dynamic connection. When no ESCD is in the communication path, this value must be set to X'01.'.

link connection. The physical equipment providing two-way communication between one link station and

one or more other link stations; for example, a telecommunication line and data circuit-terminating equipment (DCE). Synonymous with *data circuit*.

LMI. Local management interface.

local. Pertaining to a device accessed directly without use of a telecommunication line.

local area network (LAN). (1) A computer network located on a user's premises within a limited geographical area. Communication within a local area network is not subject to external regulations; however, communication across the LAN boundary may be subject to some form of regulation. (T) (2) A network in which a set of devices are connected to one another for communication and that can be connected to a larger network. See also *Ethernet* and *token ring*. (3) Contrast with *metropolitan area network (MAN)* and *wide area network (WAN)*.

logical partition (LP). A subset of the processor hardware that is defined to support the operation of a system control program (SCP). See also *logically partitioned (LPAR) mode*.

logically partitioned (LPAR) mode. A central processor complex (CPC) power-on reset mode that enables use of the PR/SM feature and allows an operator to allocate CPC hardware resources (including central processors, central storage, expanded storage, and channel paths) among logical partitions. In LPAR mode, the ESCON adapter can share a physical fiber connection with multiple host partitions.

LP. Logical partition.

LP number. Logical partition number. This allows multiple logical host partitions, LPs to share one ESCON fiber. This value is defined in the host Input/Output Configuration Program (IOCP) by the RESOURCE macro instruction. If the host is not using EMIF, use the default of 0 for the LP number.

LPAR. Logically partitioned.

LPAR mode. Logically partitioned mode.

LS. Low-speed.

LSA. Low-speed adapter (module).

M

MAN. Metropolitan area network.

Management Information Base (MIB). (1) A collection of objects that can be accessed by means of a network management protocol. (2) A definition for management information that specifies the information

available from a host or gateway and the operations allowed. (3) In OSI, the conceptual repository of management information within an open system.

MB. Megabyte (1 000 000 bytes).

Mbps. Megabits per second (1 000 000 bits per second).

metropolitan area network (MAN). A network formed by the interconnection of two or more networks which may operate at higher speed than those networks, may cross administrative boundaries, and may use multiple access methods. (T) Contrast with *local area network (LAN)* and *wide area network (WAN)*.

MIB. (1) MIB module. (2) Management Information Base.

modem (modulator/demodulator). (1) A functional unit that modulates and demodulates signals. One of the functions of a modem is to enable digital data to be transmitted over analog transmission facilities. (T) (A) (2) A device that converts digital data from a computer to an analog signal that can be transmitted on a telecommunication line, and converts the analog signal received to data for the computer.

MPC. Multi-Path Channel.

MPC+. High-Performance Data Transfer (HPDT) Multi-Path Channel.

ms. Millisecond (1/1000 second).

N

network. (1) A configuration of data processing devices and software connected for information interchange. (2) A group of nodes and the links interconnecting them.

network architecture. The logical structure and operating principles of a computer network. (T)

Note: The operating principles of a network include those of services, functions, and protocols.

network management. The process of planning, organizing, and controlling a communication-oriented data processing or information system.

NIC. Network Information Center.

NMS. Network management station.

NNI. Network-to-network interface.

non-return-to-zero change-on-ones recording (NRZ-1). A recording method in which the ones are represented by a change in the condition of

magnetization, and zeros are represented by the absence of change. Only the one signals are explicitly recorded. (Previously called *non-return-to-zero inverted*, NRZI, recording.)

NRZ-1. Non-return-to-zero change-on-ones recording.

NSAP. Network service address point.

NSC. Network Support Center.

NVDM. NetView Distribution Manager/6000.

O

OC. Optical carrier.

OSI. Open systems interconnection.

P

packet loss ratio. The probability that a packet will not reach its destination or not reach it within a specified time.

packet mode operation. Synonym for *packet switching*.

packet switching. (1) The process of routing and transferring data by means of addressed packets so that a channel is occupied only during transmission of a packet. On completion of the transmission, the channel is made available for transfer of other packets. (1) (2) Synonymous with *packet mode operation*. See also *circuit switching*.

PBX. Private branch exchange.

PCM. Pulse code modulation.

PDH. Plesiochronous digital hierarchy.

permanent virtual circuit (PVC). In X.25 and frame relay communications, a virtual circuit that has a logical channel permanently assigned to it at each data terminal equipment (DTE).

physical circuit. A circuit established without multiplexing. See also *data circuit*. Contrast with *virtual circuit*.

PM. Presentation Manager.

PMF. Parameter Management Frame.

PNP. Private numbering plan.

Point-to-Point Protocol (PPP). A protocol that provides a method for encapsulating and transmitting packets over serial point-to-point links.

port. (1) An access point for data entry or exit. (2) A connector on a device to which cables for other devices such as display stations and printers are attached. Synonymous with *socket*. (3) The representation of a physical connection to the link hardware. A port is sometimes referred to as an adapter; however, there can be more than one port on an adapter. There may be one or more ports controlled by a single DLC process. (4) In the Internet suite of protocols, a 16-bit number used to communicate between TCP or the User Datagram Protocol (UDP) and a higher-level protocol or application. Some protocols, such as File Transfer Protocol (FTP) and Simple Mail Transfer Protocol (SMTP), use the same well-known port number in all TCP/IP implementations. (5) An abstraction used by transport protocols to distinguish among multiple destinations within a host machine.

PPP. Point-to-Point Protocol.

PR/SM. Processor Resource/Systems Manager.

private branch exchange (PBX). A private telephone exchange for transmission of calls to and from the public telephone network.

problem determination. The process of determining the source of a problem; for example, a program component, machine failure, telecommunication facilities, user or contractor-installed programs or equipment, environmental failure such as a power loss, or user error.

Processor Resource/Systems Manager (PR/SM). The feature on a 3090 Processor Complex that offers flexible partitioning of a 3090 processing system into a number of logical partitions. Each partition within a PR/SM environment supports its own MVS or VSE image and VTAM, resulting in a multi-MVS or VSE environment.

PRS. Primary reference source.

PSN. Public switched network.

PSTN. Public switched telephone network.

PTM. Packet transfer mode.

PVC. Permanent virtual circuit.

Q

QoS. Quality of service.

R

rack. A metallic structure, with a standard 19-inch width, that houses Nways Switch hardware elements: logic subrack with modules, fan boxes, and power subrack with power units.

real-time processing. The manipulation of data that are required, or generated, by some process while the process is in operation. Usually the results are used to influence the process, and perhaps related processes, while it is occurring.

RETAIN. Remote Technical Assistance Information Network.

ring. See *ring network*.

ring network. (1) A network in which every node has exactly two branches connected to it and in which there are exactly two paths between any two nodes. (T)
(2) A network configuration in which devices are connected by unidirectional transmission links to form a closed path.

route. (1) An ordered sequence of nodes and transmission groups (TGs) that represent a path from an origin node to a destination node traversed by the traffic exchanged between them. (2) The path that network traffic uses to get from source to destination.

router. (1) A computer that determines the path of network traffic flow. The path selection is made from several paths based on information obtained from specific protocols, algorithms that attempt to identify the shortest or best path, and other criteria such as metrics or protocol-specific destination addresses. (2) An attaching device that connects two LAN segments, which use similar or different architectures, at the reference model network layer. Contrast with *bridge* and *gateway*. (3) In OSI terminology, a function that determines a path by which an entity can be reached.

routing. (1) The assignment of the path by which a message is to reach its destination. (2) In SNA, the forwarding of a message unit along a particular path through a network, as determined by parameters carried in the message unit, such as the destination network address in a transmission header.

RSC. Remote Support Center.

RSF. Remote Support Facility.

RT. Real time.

S

s. Second.

SDH. Synchronous digital hierarchy.

SDLC. Synchronous Data Link Control.

SDT. Structured data transfer.

Serial Line Internet Protocol (SLIP). A TCP/IP protocol used on a point-to-point connection between two IP hosts over a serial line (for example, an RS/EIA-232 connection into a modem over a telephone line).

In an NBBS network, the SLIP is used over a connection between an Nways Switch administration station (NAS) and an IBM Network Support Center (NSC).

Simple Network Management Protocol (SNMP). In the Internet suite of protocols, a network management protocol that is used to monitor routers and attached networks. SNMP is an application layer protocol. Information on devices managed is defined and stored in the application's Management Information Base (MIB).

SLA. Serial link architecture.

SLIP. Serial Line Internet Protocol.

SNA. Systems Network Architecture.

SNMP. Simple Network Management Protocol.

socket. The abstraction provided by the University of California's Berkeley Software Distribution (commonly called Berkeley UNIX or BSD UNIX) that serves as an endpoint for communication between processes or applications.

SONET. Synchronous optical network.

source route bridging. In LANs, a bridging method that uses the routing information field in the IEEE 802.5 medium access control (MAC) header of a frame to determine which rings or token-ring segments the frame must transit. The routing information field is inserted into the MAC header by the source node. The information in the routing information field is derived from explorer packets generated by the source host.

spoofing. For data links, a technique in which a protocol initiated from an end station is acknowledged and processed by an intermediate node on behalf of the final destination. In IBM 6611 data link switching, for example, SNA frames are encapsulated into TCP/IP packets for transport across a non-SNA wide area network, unpacked by another IBM 6611, and passed to

the final destination. A benefit of spoofing is the prevention of end-to-end session timeouts.

SRC. System reference code.

STM-1. Synchronous transport module-1.

SW. Switch (module).

SWRD. Switch redrive (module).

synchronous. (1) Pertaining to two or more processes that depend upon the occurrence of specific events such as common timing signals. (T)

(2) Occurring with a regular or predictable time relationship.

Synchronous Data Link Control (SDLC). A discipline conforming to subsets of the Advanced Data Communication Control Procedures (ADCCP) of the American National Standards Institute (ANSI) and High-level Data Link Control (HDLC) of the International Organization for Standardization, for managing synchronous, code-transparent, serial-by-bit information transfer over a link connection. Transmission exchanges may be duplex or half-duplex over switched or nonswitched links. The configuration of the link connection may be point-to-point, multipoint, or loop. (I) Contrast with *binary synchronous communication (BSC)*.

synchronous optical network (SONET). A US standard for transmitting digital information over optical interfaces. It is closely related to the synchronous digital hierarchy (SDH) recommendation.

system. In data processing, a collection of people, machines, and methods organized to accomplish a set of specific functions. (I) (A)

Systems Network Architecture (SNA). The description of the logical structure, formats, protocols, and operational sequences for transmitting information units through, and controlling the configuration and operation of, networks. The layered structure of SNA allows the ultimate origins and destinations of information, that is, the end users, to be independent of and unaffected by the specific SNA network services and facilities used for information exchange.

T

TCP. Transmission Control Protocol.

TCP/IP. Transmission Control Protocol, Internet Protocol.

TDM. Time division multiplexing.

Telnet. In TCP/IP, an application protocol that allows a user at one site to access a remote system as if the user's display station were locally attached. Telnet uses the Transmission Control Protocol as the underlying protocol.

TFTP. Trivial File Transfer Protocol.

time division multiplexing (TDM). See *channelization*.

TN3270. An informally defined protocol for transmitting 3270 data streams over Telnet.

TN3270. An informally defined protocol for transmitting 3270 data streams over Telnet.

token. (1) In a local area network, the symbol of authority passed successively from one data station to another to indicate the station temporarily in control of the transmission medium. Each data station has an opportunity to acquire and use the token to control the medium. A token is a particular message or bit pattern that signifies permission to transmit. (T) (2) In LANs, a sequence of bits passed from one device to another along the transmission medium. When the token has data appended to it, it becomes a frame.

token ring. (1) According to IEEE 802.5, network technology that controls media access by passing a token (special packet or frame) between media-attached stations. (2) A FDDI or IEEE 802.5 network with a ring topology that passes tokens from one attaching ring station (node) to another. (3) See also *local area network (LAN)*.

Transmission Control Protocol (TCP). A communications protocol used in Internet and in any network that follows the U.S. Department of Defense standards for internetwork protocol. TCP provides a reliable host-to-host protocol between hosts in packet-switched communications networks and in interconnected systems of such networks. It assumes that the Internet protocol is the underlying protocol.

Transmission Control Protocol/Internet Protocol (TCP/IP). A set of communications protocols that support peer-to-peer connectivity functions for both local and wide area networks.

Transmission Control Protocol/Internet Protocol (TCP/IP). A set of communication protocols that support peer-to-peer connectivity functions for both local and wide area networks.

transparent bridging. In LANs, a method for tying individual local area networks together through the medium access control (MAC) level. A transparent bridge stores the tables that contain MAC addresses so that frames seen by the bridge can be forwarded to another LAN if the tables indicate to do so.

Trivial File Transfer Protocol (TFTP). In the Internet suite of protocols, a protocol for file transfer that requires minimal overhead and minimal capability. TFTP uses the connectionless datagram delivery services of the User Datagram Protocol (UDP), which allows hosts that have no disk storage to implement TFTP in read-only memory (ROM) and use it to boot themselves.

U

UDP. User Datagram Protocol.

UNI. User network interface (protocol).

UTP. Unshielded twisted pair.

V

V ac. Volts alternating current.

V.24. In data communications, a specification of the CCITT that defines the list of definitions for interchange circuits between data terminal equipment (DTE) and data circuit-terminating equipment (DCE).

V.25. In data communications, a specification of the CCITT that defines the automatic answering equipment and parallel automatic calling equipment on the General Switched Telephone Network, including procedures for disabling of echo controlled devices for both manually and automatically established calls.

V.35. In data communications, a specification of the CCITT that defines the list of definitions for interchange circuits between data terminal equipment (DTE) and data circuit-terminating equipment (DCE) at various data rates.

V.36. In data communications, a specification of the CCITT that defines the list of definitions for interchange circuits between data terminal equipment (DTE) and data circuit-terminating equipment (DCE) at rates of 48, 56, 64, or 72 kilobits per second.

version. A separately licensed program that usually has significant new code or new function.

virtual circuit. (1) In packet switching, the facilities provided by a network that give the appearance to the user of an actual connection. (T) See also *data circuit*. Contrast with *physical circuit*. (2) A logical connection established between two DTEs.

virtual connection. In frame relay, the return path of a potential connection.

VPD. Vital product data.

W

WAN. Wide area network.

wide area network (WAN). (1) A network that provides communication services to a geographic area larger than that served by a local area network or a metropolitan area network, and that may use or provide public communication facilities. (T) (2) A data communications network designed to serve an area of hundreds or thousands of miles; for example, public and private packet-switching networks, and national telephone networks. Contrast with *local area network (LAN)* and *metropolitan area network (MAN)*.

X

X.21. An International Telegraph and Telephone Consultative Committee (CCITT) recommendation for a general-purpose interface between data terminal equipment and data circuit-terminating equipment for synchronous operations on a public data network.

X.25. An International Telegraph and Telephone Consultative Committee (CCITT) recommendation for the interface between data terminal equipment and packet-switched data networks. See also *packet switching*.

Index

Numerics

- 2216
 - power
 - on 5-8
- 2216 firmware
 - boot sequence 4-5
 - configuration management 4-3
 - function keys 4-2
 - help 4-2
 - mode of operation 4-1
 - testing a device 4-7
 - using 4-1
 - utilities, using 4-8
- 2216 FRU exchange 2-3
- 2216 problem determination
 - basic verification 1-5
 - service terminal display unreadable 1-10

A

- access methods, physical 3-1
- accessing the 2216
 - local access 3-3
- accessing the IBM 2216 3-1, 5-1
- active file status D-1
- adapter
 - diagnostics 5-9
 - power on 5-8
 - test 5-8
- adapter card status 1-3
- adapter plugging E-2
- adapter wrap plugs 1-14
- adapter, inserting 2-16
- addresses, IP 4-19
- AIB test 5-15
- ASCII terminal 3-3
- ASCII terminal, connection to 2216 3-3
- assumptions E-2
- attended mode 4-1
- attributes for ASCII terminal 3-3
- avail file status D-2

B

- bank for operational software images D-1
- boot config, TFTP file transfer in D-2
- boot configuration commands D-1
- boot sequence 4-5
- broken file status D-2

C

- cable
 - duplex-to-biconic test 5-16
- change management 3-5, D-1
- change management functions D-8
- change supervisory password 4-13
- code updates D-5
- command line interface 5-8
- common tasks F-1
- config as seen in change management D-1
- configuration management 4-3
- connecting power cord 2-2
- control panel functions 1-1
- copy command in change management D-9
- corrections, documentation x
- coupler, duplex-to-duplex 5-16

D

- dead man timer, manipulating 4-20
- describe config images D-8
- describe load images D-8
- Device List Page panel 5-2
- Device Status and Control Menu panel 5-4, 5-10, 5-13
- device test 4-7
- diagnostics
 - adapter 5-9
 - Diagnostic Menu panel 5-9
 - interactive test options 5-15
 - optical power measurement test 5-16
 - setup for optical test 5-17
 - Test Options panel 5-15, 5-16
- diagnostics, operational 5-1
- disable dumping D-8
- downloading files to the IBM 2216 D-1
- dumping, disabling D-8
- dumping, enabling D-8
- duplex-to-biconic test cable 5-16
- duplex-to-duplex coupler 5-16

E

- enable dumping D-8
- equipment, for FRU removal and replacement 2-1
- error log, displaying 4-16
- ESCON diagnostic tests 5-12

F

- factory plugging defaults E-1
- file statuses D-1

- file transfer D-9
- file transfer using TFTP D-2
- file transfer using Xmodem D-4
- firmware 4-1
 - help 4-2
- fixes x
- function keys 3-4, 4-2

H

- help x
- help panels 4-2
- http site x

I

- image of the operational software D-1
- insert adapter 2-16
- interactive test options 5-15
- interface wrap plugs 1-14
- IP addresses 4-19
- IPL, setting up remote 4-19

L

- light reception test 5-12, 5-15
- local file status D-2

M

- managing software files D-1
- managing the configuration 4-3
- memory 2-11
- memory DIMMs
 - inserting 2-16
 - removing 2-11
 - replacing 2-11
- messages
 - TTY console 5-8
- methods of access 3-1
- microcode D-1
- migrating to a new code level D-5

O

- OPCON
 - command line interface 5-8
 - description 5-8
- operating code D-5
- operational diagnostics 5-1
 - command line interface 5-2
- operator control module (OPCON) 5-8
- optical power
 - meter 5-16
 - Setup for Optical Test panel 5-17
 - test 5-15, 5-16

- Optical Test in Progress panel 5-18

P

- panels
 - Device List Page 5-2
 - Device Status and Control Menu 5-4, 5-10, 5-13
 - Diagnostic Menu 5-9
 - Optical Test in Progress 5-18
 - Restore from Light Reception Test 5-13
 - Restore from Light Reception Test panel 5-13
 - Restore From Wrap Test 5-11
 - Setup for Light Reception Test 5-12
 - Setup for Optical Test 5-17
 - Setup for Wrap Test 5-10
 - Test Options 5-9, 5-12, 5-16
 - Test Results 5-11, 5-14
- parts catalog B-1
- password, supervisory 4-9, 4-10
 - removing 4-13
- pending file status D-2
- physical access methods 3-1
- plugging defaults E-1
- plugging sequences E-1
- Power Cord 2-2
- power cord, removal and replacement 2-2
- power meter, optical 5-16
- power on
 - 2216 5-8
 - adapter 5-8
 - power supply status 1-3
 - power test, optical 5-15
 - problem determination 1-1

R

- rack-mounting removal procedure 2-19
- reload D-2
- removing the IBM 2216 from the rack 2-19
- repair equipment 2-1
- resetting the IBM 2216 D-2
- restart D-2
- Restore From Wrap Test panel 5-11

S

- selecting a device to test 4-7
- selecting the boot sequence 4-5
- sending configuration files from the Configuration Program D-7
- service kit 1-14
- service terminal display unreadable 1-10
- setting the power-on password 4-9
- settings, ASCII terminal 3-3
- setup attributes, ASCII terminal 3-3

- Setup for Light Reception Test panel 5-12
- Setup for Optical Test panel 5-17
- Setup for Wrap Test panel 5-10
- slots and adapters E-2
- software D-1
- software and configuration change management 3-5
- start mode
 - disabling 4-12
 - enabling 4-11
- starting firmware 4-2
- supervisory password 4-9, 4-10
 - removing 4-13
- system card status 1-3

T

- tasks, common F-1
- terminal settings 3-3, 3-4
- terminal, ASCII 3-3
- terminal, attachment to 2216 3-3
- test
 - adapter 5-8
 - AIB 5-15
 - cable, duplex-to-biconic 5-16
 - Device Status and Control Menu panel 5-4, 5-10, 5-13
 - interactive options 5-15
 - light reception 5-15
 - optical power 5-15, 5-16
 - Restore from Light Reception Test panel 5-13
 - Restore From Wrap Test panel 5-11
 - Test Options panel 5-9, 5-12, 5-15, 5-16
 - Test Results panel 5-11, 5-14
 - wrap plug 5-15
- Test Options panel 5-9, 5-12
- Test Results panel 5-11, 5-14
- testing a device 4-7
- TFTP for file transfer D-2
- tools
 - FRU removal and replacement 2-1
- TTY console messages 5-8

U

- Unattended mode 4-1
- Unattended start mode
 - disabling 4-12
 - enabling 4-11
- updates x
- updating software to new level D-5
- updating system firmware 4-14
- using the utilities 4-8
- utilities, using 4-8

V

- vital product data 4-17

W

- web sites x
- wrap plug test 5-15
- wrap plugs 1-14

X

- Xmodem for file transfer D-4
- Xmodem software selection 4-21

Tell Us What You Think!

2216 Nways Multiaccess Connector Service and Maintenance Manual

Publication No. SY27-0350-02

We hope you find this publication useful, readable, and technically accurate, but only you can tell us! Your comments and suggestions will help us improve our technical publications. Please take a few minutes to let us know what you think by completing this form. If you are in the U.S.A., you can mail this form postage free or fax it to us at 1-800-253-3520. Elsewhere, your local IBM branch office or representative will forward your comments or you may mail them directly to us.

Overall, how satisfied are you with the information in this book?	Satisfied	Dissatisfied
	<input type="checkbox"/>	<input type="checkbox"/>

How satisfied are you that the information in this book is:	Satisfied	Dissatisfied
Accurate	<input type="checkbox"/>	<input type="checkbox"/>
Complete	<input type="checkbox"/>	<input type="checkbox"/>
Easy to find	<input type="checkbox"/>	<input type="checkbox"/>
Easy to understand	<input type="checkbox"/>	<input type="checkbox"/>
Well organized	<input type="checkbox"/>	<input type="checkbox"/>
Applicable to your task	<input type="checkbox"/>	<input type="checkbox"/>

Specific comments or problems:

Please tell us how we can improve this book:

Thank you for your comments. If you would like a reply, provide the necessary information below.

Name

Address

Company or Organization

Phone No.



Fold and Tape

Please do not staple

Fold and Tape



NO POSTAGE
NECESSARY
IF MAILED IN THE
UNITED STATES

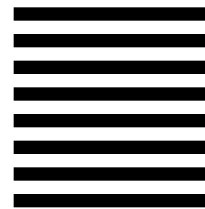

BUSINESS REPLY MAIL

FIRST-CLASS MAIL PERMIT NO. 40 ARMONK, NEW YORK

POSTAGE WILL BE PAID BY ADDRESSEE

Design & Information Development
Dept. CGF/Bldg. 656
International Business Machines Corporation
PO BOX 12195
RESEARCH TRIANGLE PARK NC 27709-9990



Fold and Tape

Please do not staple

Fold and Tape



Part Number: 08L2191

2216 Publications:

2216 Nways Multiaccess Connector:

- GA27-4105 *Introduction and Planning Guide*
- GA27-4106 *Installation and Initial Configuration Guide*
- SY27-0350 *Service and Maintenance Manual*
- GX27-3988 *Hardware Configuration Quick Reference Card*
- SD21-0030 *Caution: Safety Information—Read This First*

Nways Multiprotocol Access Services:

- SC30-3886 *Software User's Guide*
- SC30-3884 *Protocol Configuration and Monitoring Reference, Volume 1*
- SC30-3885 *Protocol Configuration and Monitoring Reference, Volume 2*

Multipurpose Publications:

- SC30-3682 *Nways Event Logging System Messages Guide*
- GC30-3830 *Configuration Program User's Guide*

Supplemental information:

- SG24-4957 *IBM 2216 Nways Multiaccess Connector Description and Configuration Scenarios - Volume I (HW and Basic Multiprotocol)*
- SG24-4956 *IBM 2210 Nways Multiprotocol Router and IBM 2216 Nways Multiaccess Connector Description and Configuration Scenarios - Volume II (SNA and ATM)*

